

### FLOW METER LIMITED WARRANTY

Meters are warranted against defects in materials and workmanship to the original user for a period of thirteen (13) months from the date of factory shipment, provided the meter is installed, operated and maintained in accordance with King Instrument Company's instructions and recommendations.

This warranty does not apply if failure is caused or contributed to by any of the following: improper handling, improper storage, abuse, unsuitable application of the product, lack of reasonable and necessary maintenance, use exceeding suggested pressure and temperature maximums, improper packaging for return, or repairs made or attempted to be made by anyone other than King Instrument Company, Inc.

KING INSTRUMENT COMPANY, INC. MAKES NO WARRANTY AS TO THE FITNESS OF ITS PRODUCTS FOR SPECIFIC APPLICATIONS.

This warranty is valid for the original end-user only and does not apply to products that have been damaged or modified. This warranty is non-transferrable and is limited to replacement or repair. The liability of King Instrument Company arising out of its supply of the products, or their use, shall not in any case exceed the cost of correcting defects in the products as set forth above.

THIS WARRANTY IS A LIMITED WARRANTY AND SHALL BE IN LIEU OF ANY OTHER WARRANTIES, EXPRESSED OR IMPLIED, INCLUDING BUT NOT LIMITED TO ANY IMPLIED WARRANTY OR MERCHANTABILITY OR FITNESS FOR A PARTICULAR PURPOSE. THERE ARE NO OTHER WARRANTIES WHICH EXIST BEYOND THE DESCRIPTION OR FACE HEREOF.

IN NO EVENT SHALL KING INSTRUMENT COMPANY BE LIABLE FOR LOSS OF PROFITS, INDIRECT, CONSEQUENTIAL OR INCIDENTAL DAMAGES.

Products should be returned, prepaid, to King Instrument Company, Inc. with proof of purchase. Call factory for Return Merchandise Authorization (RMA) number and return instructions.

### THIS IS IMPORTANT INFORMATION. READ IT CAREFULLY BEFORE BEGINNING WORK.

- 1) Inspect meter for damage that may have occurred during shipping. Report any damage to the container to the freight carrier immediately.
- 2) Make sure your pressure, temperature, fluid and other requirements are compatible with the meter (including o-rings.)
- 3) Select a suitable location for installation to prevent excess stress on the meter which may result from:
  - a) Misaligned pipe.
  - b) The weight of related plumbing.
  - c) "Water Hammer" which is most likely to occur when flow is suddenly stopped as with quick closing solenoid operated valves. (If necessary, a surge chamber should be installed. This will also be useful in pressure start-up situations.)
  - d) Thermal expansion of liquid in a stagnated or valve isolated system.
  - e) It is recommended to install valving which will allow the meter to be drained. Meter should be drained when not in use or prior to maintenance.
  - f) Instantaneous pressurization which will stress the meter and could result in tube failure.
- 4) Handle the meter carefully during installation.
  - a) Use an appropriate amount of teflon tape on external pipe threads before making connections. Do not use paste or stick type thread sealing products.
- 5) Install the meter vertically with the inlet port at the bottom.
- 6) Meters with stainless steel fittings will support several feet of pipe as long as significant vibration or stress resulting from misaligned pipe are not factors.
- 7) Meters used in gas service should have suitable valves plumbed in at the inlet and outlet of the meter. These valves should be no more than 1-1/2 pipe diameters from the meter ports. The valve at the outlet should be used to create back pressure as required to prevent float bounce. It should be set initially and then left alone. The inlet valve should be used for throttling purposes. Depending on the installation, valves may not be essential, but they are most useful in many installations. Remember: To get a correct reading of flow in gas service, it is necessary to know the pressure right at the outlet of the meter (before the valve).
- 8) Pressure and temperature maximums must never be exceeded.

**NOTE:** In closed thermal transfer or cooling systems, install the meter in the cool side of the line to minimize meter expansion and contraction and possible fluid leaks at the threaded connections.

Maximum Non-Shock Pressure and Temperature	
Temperature	Pressure
200° F	200 psig
Ambient Temp. 33° F -125° F	

## CAUTION

- 7450 Series meters have o-ring seals. Use with incompatible fluid may cause o-rings to swell which may cause glass tube to fail.
- Extra caution must be exercised when meters are used in high pressure gas cylinder applications. Pressure regulators should be installed at the cylinder and at the inlet of the meter.
- Serious property damage and great personal injury could occur as the result of a meter misused or used in an unsuitable application.

## CLEANING

Carefully remove the flowmeter from the piping system. Remove the front and back shield. Remove the end fittings using a  $\frac{7}{8}$ " wrench. Using a  $\frac{3}{16}$ " hex key, back off the compression screw by turning counter clockwise. This will release the compression of the glass tube. Carefully remove the screws that hold the outlet block. Remove the outlet block and internals. Remove glass tube.

**Valve Models:** Remove valve from the bottom block using a  $\frac{7}{8}$ " open ended wrench. Disassembly of valve is not recommended. Outer valve o-ring should be replaced during meter maintenance and cleaning.

All components are now fully accessible for cleaning. Components can be cleaned with a mild soap solution. This will be an effective cleaner of rust stains. A bottle brush may be helpful in cleaning the inside of the glass tube. Caution must be used so that materials of construction are not damaged by cleaning solutions. Hard water deposits can be removed with a 5% acetic acid solution (vinegar). Before the meter is reassembled, inspect all parts for damage. O-rings should be replaced during meter maintenance and cleaning.

To reassemble, position the glass tube on the bottom block and center onto bottom gasket. Insert float, if on a guide rod make sure the bottom end of the guide rod is inserted into the center hole of the bottom float stop. Re-install the outlet block. Using a  $\frac{3}{16}$ " hex key turn compression screw counterclockwise while keeping the glass tube centered between the bottom and top gaskets. Re-install end fittings, valve and shields.

## REPAIR

7450 meters that require repair should be sent to the factory. Please call for a Return Merchandise Authorization (RMA) number and return instructions.

## WARNING:

Pressure and temperature ratings are based on a study of the engineering data for particular materials used in construction and on the design of individual models. This information is supplemented by destructive test results. Meters with stainless enclosures must never be operated without shields securely in place. Meters exposed to difficult environments such as those created by certain chemicals, excessive vibration or other stress inducing factors could fail at or below the suggested maximums. Never operate meters above pressure and temperature maximums. It is strongly recommended that all meter installations utilize an appropriate pressure relief valve and/or rupture disc. The pressure settings and locations of these devices should be such that meters cannot be over pressurized. Meter failure could result in damage to equipment and serious personal injury. Always use suitable safety gear, including OSHA approved eye protection when working around meters in service. We are happy to pass along chemical compatibility information that has been published by the manufacturer's of raw materials used in our products; however, this information should not be construed as a recommendation made by King Instrument Company, Inc. for a specific application.

## FLOAT TYPES AND ORIENTATIONS



GV FLOAT

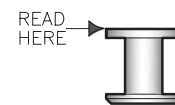

LP FLOAT

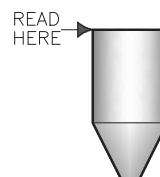

SL FLOAT

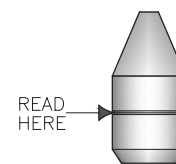

SP FLOAT

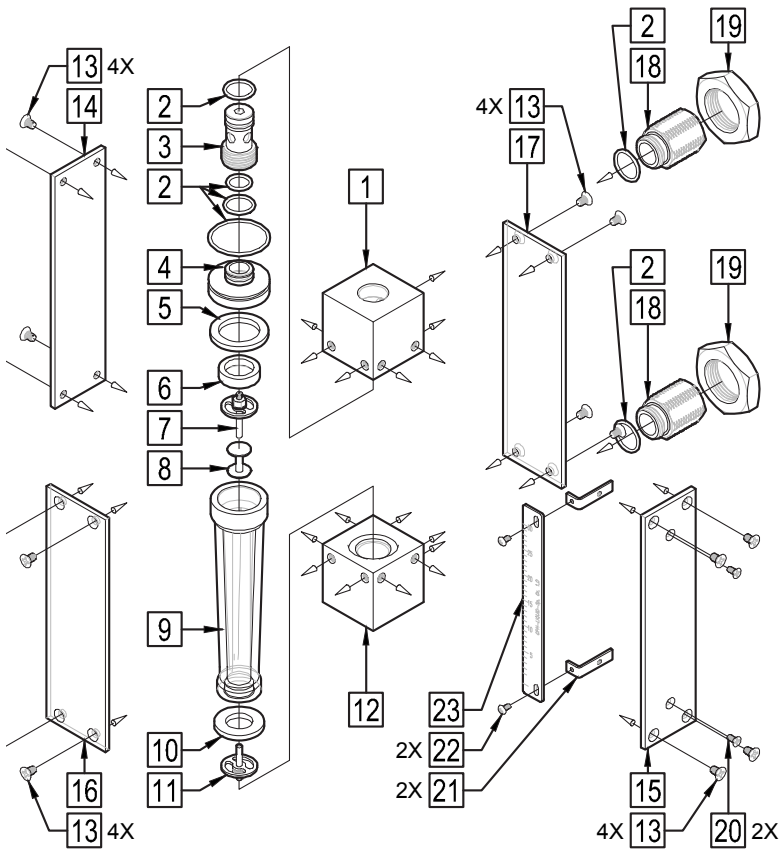

## 7450 SERIES ASSEMBLY 3G1-G/6G1-6G3 NON-VALVE PARTS LIST:

- |   |                               |
|---|-------------------------------|
| 1. Outlet End Fitting Block               | 12. Inlet And Fitting Block   |
| 2. O-Ring                                 | 13. Side Plate / Shield Screw |
| 3. Compression Fitting                    | 14. Side Plate                |
| 4. Compression Seat                       | 15. Scale Side Plate          |
| 5. Outlet Seal                            | 16. Shield (Clear)            |
| 6. Outlet Float Stop Holder               | 17. Shield (White)            |
| 7. Outlet Float Stop / Extension Assembly | 18. End Fitting               |
| 8. Float                                  | 19. End Fitting Nut           |
| 9. Glass Meter Tube                       | 20. Scale Bracket Screw       |
| 10. Inlet Seal                            | 21. Scale Bracket             |
| 11. Inlet Float Stop / Extension Assembly | 22. Scale Plate Screw         |
|   | 23. Scale Plate               |

## 7450 SERIES ASSEMBLY 3G1-3G3/6G1-6G3 INLET VALVE PARTS LIST:

- |   |                               |
|---|-------------------------------|
| 1. Outlet End Fitting Block               | 12. Inlet And Fitting Block   |
| 2. O-Ring                                 | 13. Side Plate / Shield Screw |
| 3. Compression Fitting                    | 14. Side Plate                |
| 4. Compression Seat                       | 15. Scale Side Plate          |
| 5. Outlet Seal                            | 16. Shield (Clear)            |
| 6. Outlet Float Stop Holder               | 17. Shield (White)            |
| 7. Outlet Float Stop / Extension Assembly | 18. End Fitting               |
| 8. Float                                  | 19. End Fitting Nut           |
| 9. Glass Meter Tube                       | 20. Scale Bracket Screw       |
| 10. Inlet Seal                            | 21. Scale Bracket             |
| 11. Inlet Float Stop / Extension Assembly | 22. Scale Plate Screw         |
|   | 23. Scale Plate               |
|   | 24. Valve Assembly            |

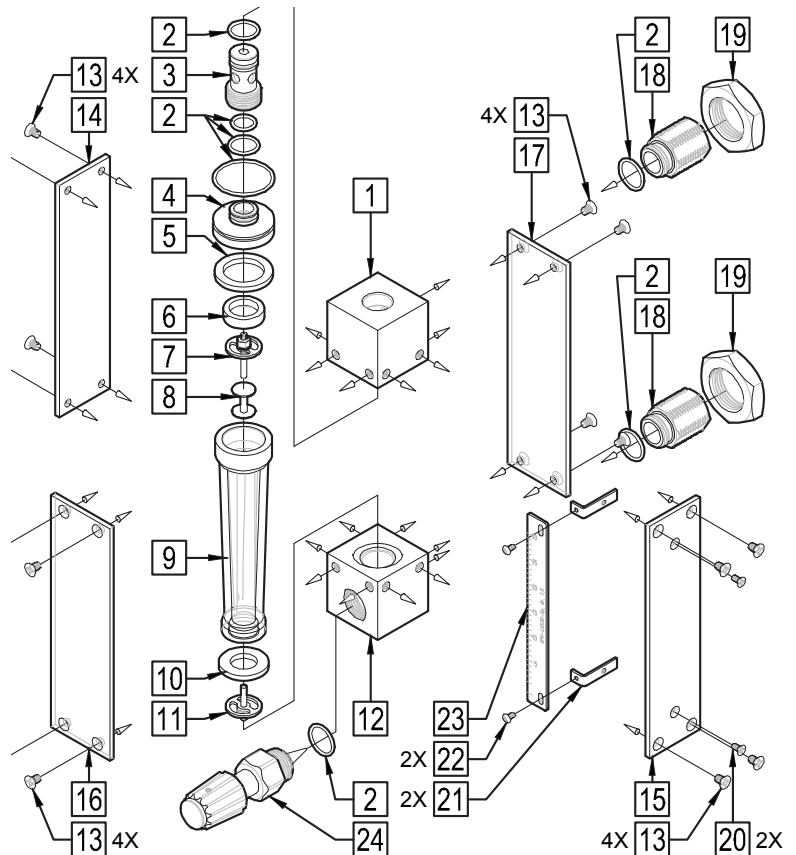

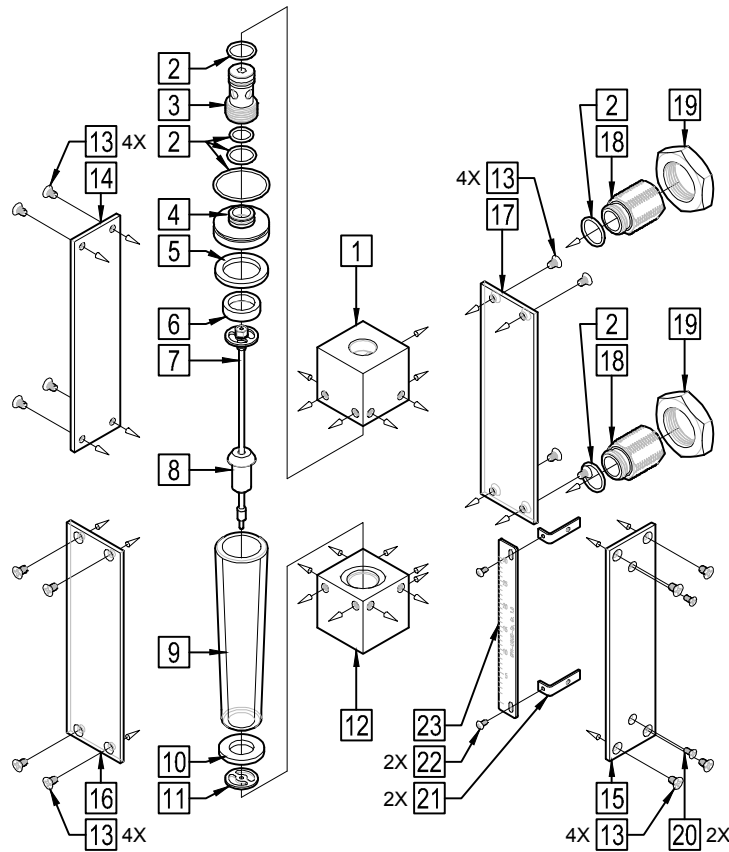

## 7450 SERIES ASSEMBLY 3P1-3P3/6P1-6P3 NON-VALVE PARTS LIST:

- |                                    |                               |
|------------------------------------|-------------------------------|
| 1. Outlet End Fitting Block        | 13. Side Plate / Shield Screw |
| 2. O-Ring                          | 14. Side Plate                |
| 3. Compression Fitting             | 15. Scale Side Plate          |
| 4. Compression Seat                | 16. Shield (Clear)            |
| 5. Outlet Seal                     | 17. Shield (White)            |
| 6. Outlet Float Stop Holder        | 18. End Fitting               |
| 7. Float Stop / Guide Rod Assembly | 19. End Fitting Nut           |
| 8. Float                           | 20. Scale Bracket Screw       |
| 9. Glass Meter Tube                | 21. Scale Bracket             |
| 10. Inlet Seal                     | 22. Scale Plate Screw         |
| 11. Inlet Float Stop               | 23. Scale Plate               |
| 12. Inlet And Fitting Block        |                               |

## 7450 SERIES ASSEMBLY 3P1-3P3/6P1-6P3 INLET VALVE PARTS LIST:

- |                                    |                               |
|------------------------------------|-------------------------------|
| 1. Outlet End Fitting Block        | 13. Side Plate / Shield Screw |
| 2. O-Ring                          | 14. Side Plate                |
| 3. Compression Fitting             | 15. Scale Side Plate          |
| 4. Compression Seat                | 16. Shield (Clear)            |
| 5. Outlet Seal                     | 17. Shield (White)            |
| 6. Outlet Float Stop Holder        | 18. End Fitting               |
| 7. Float Stop / Guide Rod Assembly | 19. End Fitting Nut           |
| 8. Float                           | 20. Scale Bracket Screw       |
| 9. Glass Meter Tube                | 21. Scale Bracket             |
| 10. Inlet Seal                     | 22. Scale Plate Screw         |
| 11. Inlet Float Stop               | 23. Scale Plate               |
| 12. Inlet End Fitting Block        | 24. Valve Assembly            |

