



A **Halma** company

OPERATING MANUAL

ELECTRONIC PRESSURE AND VACUUM CONTROLLERS

Models EPCD • EPC



Thank you for purchasing your OEM pressure controllers.

Contact Information

Alicat Scientific

World Headquarters

7641 N Business Park Dr., Tucson, AZ 85743 USA

info@alicat.com • alicat.com • +1 888-290-6060

India

india@alicat.com

M/s Halma India Pvt. Ltd.
C/O Avire India Pvt. Ltd.
Plot #A-147, Rd. #24
Wagale Ind. Estate, Thane
(West) 400604,
Maharashtra, India
+1 888-290-6060

China & SE Asia

info-cn@alicat.com

alicat.com.cn
2nd Floor, Block 63, No.
421, Hong Cao Rd,
Shanghai, PRC 200233
+86-21-60407398 ext.
801

Europe

europa@alicat.com

Geograaf 24
6921 EW Duiven
The Netherlands
+31 (0) 26 203.1651



This device comes with a NIST traceable calibration certificate.



This device conforms to the European Union's Restriction of Use of Hazardous Substances in Electrical and Electronic Equipment (RoHS) Directive 2011/65/EU.



This device complies with the requirements of the Low Voltage Directive 2014/35/EU and the EMC Directive 2014/30/EU and carries the CE Marking accordingly.



This device complies with the requirements of the European Union's Waste Electrical & Electronic Equipment (WEEE) Directive 2002/96/EC

Contents

Getting Started	4
Mounting	4
Plumbing	5
Process Ports	5
Maximum Pressure	5
Pressure Controller Operation	5
Power and Signal Connections	7
RS-232 or RS-485 Digital Signals	7
Analog Signals	8
Serial Communication	8
Polling Mode	9
Streaming Mode	9
Taring	10
Collecting Pressure Data	10
Commanding a New Setpoint	11
Sending Setpoints as Floating Point Numbers	11
Sending Setpoints as Integers	12
PID Tuning:	13
Changing Gain Values	13
Tuning the PD/PDF control algorithm	13
Tuning the PD ² I control algorithm	14
Troubleshooting valve performance with PID tuning	14
Quick Command Guide	15
Maintenance	16
Cleaning	16
Recalibration	16

Getting Started

Mounting

EPC and EPCD-Series controllers have mounting holes for convenient mounting to flat panels. These controllers are position insensitive and can be mounted in any orientation.

EPC

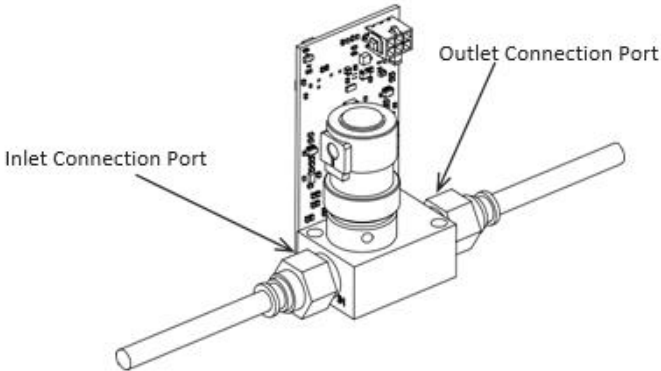

EPCD

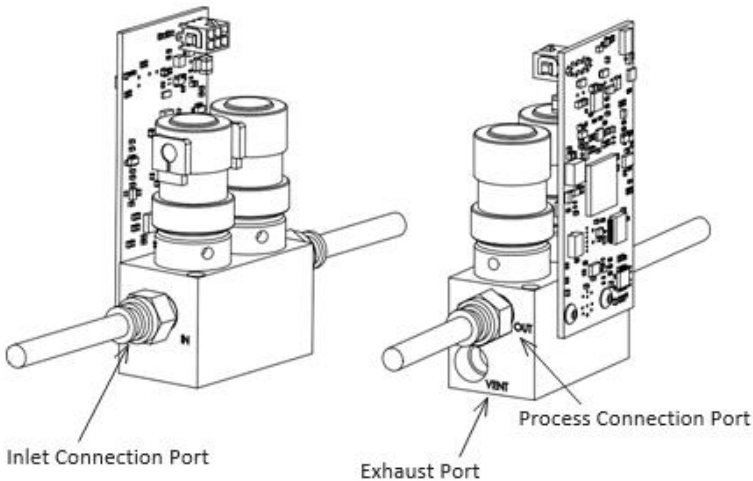

Caution: Minimize physical handling of the exposed circuit board of the EPC or EPCD while installing. Hold the circuit board on its edges while installing, in order to minimize contact with the exposed circuit board of the EPC or EPCD.

Plumbing

Process Ports

Your instrument is shipped with plastic plugs fitted in the port openings. To lessen the chance of contaminating the flow stream do not remove these plugs until you are ready to install the device.

Controllers with M5 (10-32) ports have O-ring face seals and require no sealant or tape. Do not use tape with welded or O-ring fittings.

For non M5 (10-32) ports use thread sealing Teflon® tape to prevent leakage around the port threads.

Do not wrap the first two threads. This will minimize the possibility of getting tape into the flow stream and flow body.



Warning: Do not use pipe dopes or sealants on the process connections, as these compounds can cause permanent damage to the controller should they get into the flow stream.

When changing fittings, carefully clean any tape or debris from the port connections.

Maximum Pressure

Both the valve and the sensor can be damaged from over-pressurization. The valves on an EPC or EPCD are rated to 150 PSIG, unless custom-ordered. The burst pressure of the pressure sensor is 3x the full scale, and permanent damage will occur if this is exceeded.

Pressure Controller Operation

The response time of the system will depend on the size of the volume being controlled, the operating conditions, and the PID tuning of the device. The controllers are intended for use with clean, non-corrosive gases only.

EPC Single Valve Controller

Alicat Scientific EPC-Series Pressure Controllers incorporate a digital pressure gauge with a single control valve and circuitry. The integrated control algorithm measures the pressure, compares it with the setpoint, and adjusts the valve accordingly at 1000 times per second.

The response time of the system will depend on the operating conditions and the PID tuning of the device.

EPC-Series Pressure Controllers are normally intended to control the process pressure downstream of the controller. In order for this to occur, a supply pressure greater than the full scale pressure control range of the device should be connected to the “IN” port.

EPC-Series Pressure Controllers can also be configured as back pressure controllers, opening to release pressure upstream of the controller, and closing to increase restriction and increase pressure upstream of the controller. EPC Back Pressure controllers will have a “DS” in the part number.

EPCD Dual Valve Controller

Alicat Scientific EPCD-Series Closed Volume Pressure Controllers incorporate a digital pressure gauge with dual control valves and circuitry. The integrated PID loop measures the pressure, compares it with the setpoint, and adjusts either the Inlet or Exhaust valve accordingly at 1000 times per second.

They are designed with a feed port, a process port, and an exhaust port. This allows the controllers to raise and lower the pressure of a closed system within the operating range of the controller without wasting gas under constant pressure conditions.

- Connect your EPCD into your process via the “OUT” port of the unit. This is the “Process” port.
- Connect a supply pressure greater than the full scale pressure control range of the device to the “IN” port.
- The “VENT” port can vent to atmosphere or be tied to a vacuum source as the application demands.



Note: The pressure at the vent port should be at atmospheric pressure or below to allow the controller to be used over its full scale range.

Power and Signal Connections

Power and communications are supplied through the 6 pin Molex Micro-Fit 3.0 connector:

Pin	Function
1	Power in
2	0-5 Vdc <i>Optional: 1-5 Vdc or 0-10 Vdc output signal</i>
3	Ground (common for power, digital communications, and analog signals)
4	Serial RS-232TX output signal <i>Optional: RS-485 B</i>
5	Serial RS-232RX input signal <i>Optional: RS-485 A</i>
6	Analog setpoint input

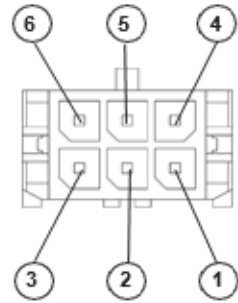

Caution: Do not apply power to pins 2, 4, 5, or 6. Permanent damage can occur.

RS-232 or RS-485 Digital Signals

To use the RS-232 or RS-485 input signal, connect the RS-232 / RS-485 Output Signal (Pin 4), the RS-232 / RS-485 Input Signal (Pin 5), and Ground (Pin 3) to your computer serial port as shown below.

DB9 to MF6 Connection for RS-232 or RS-485 Signals

9-Pin Serial Connection		MF6 Connection	
Pin	Function	Pin	Function
5	Ground	3	Ground
3	Transmit	5	Receive
2	Receive	4	Transmit

Analog Signals

Analog Output

Most devices include a primary analog output signal, which is linear over its entire range. For ranges that start at 0 Vdc, a zero-pressure condition is indicated at approximately 0.010 Vdc. Full scale pressure is indicated by the top of the range: 5 Vdc for 0-5 Vdc, 10 Vdc for 0-10 Vdc, and so on.

Serial Communication

Establishing Serial Communication

After connecting your flow controller using a communications cable, you will need to establish serial communications through a real or virtual COM port on your computer or programmable logic computer (PLC).

- If you have connected your device to a serial port, note its COM port number. This can be found in Windows® Device Manager.
- If you have a serial to USB adapter, plug it into your computer, ensure the proper driver is installed, and note the COM port number.

The controller will be configured with the following settings:

- **Baud:** 19200 (default; others can be used if the computer, its software and the controller are all set to the same rate)
- **Data bits:** 8
- **Parity:** none
- **Stop bits:** 1
- **Flow control:** none

Alicat devices use ASCII commands which are easily used in a serial terminal or integrated into a PLC.



Note: In what follows,  indicates an ASCII carriage return (decimal 13, hexadecimal D). Serial commands are not case-sensitive.

Polling Mode

Controllers are shipped in polling mode with a unit ID of A, unless requested otherwise. Each poll returns one line of data. To poll, simply enter its unit ID.

Poll the device: `[unit ID]↵`

Example: `a↵` (polls unit A)

You can change the unit ID of a polling device by typing:

Change the unit ID: `[current unit ID]@[desired unit ID]↵`

Example: `a@b↵` (changes unit A to unit B)



Warning: Care should be taken not to assign the same unit ID to more than one device on a single COM port.

Streaming Mode

In streaming mode, your device continuously and automatically sends a line of live data at regular intervals. Only one unit on a COM port may be in streaming mode at a time.



Note: RS-485 does not support streaming mode

To put your controller into streaming mode, type:

Begin streaming: `[unit ID]@=@↵`

Example: `A@=@↵` (Begins streaming unit A)

This is equivalent to changing the unit ID to “@”. To take the flow controller out of streaming mode, assign it a unit ID by typing:

Stop streaming: `@@[desired unit ID]↵`

Example: `@@=a↵` (stops and assigns unit ID of A)

When sending a command in streaming mode, the flow of data will not stop while the user is typing. This may make the commands you type unreadable. If the device does not receive a valid command, it will ignore it. If in doubt, simply hit `↵` and start again.

The default streaming interval is 50 ms, but this can be increased by changing Register 91 while the device is in polling mode:

Set streaming interval: `[unit ID]w91=[time in milliseconds]↵`

Example: `aw91=500↵` (streams data every 500 ms)

Taring

Taring pressure aligns the internal gauge pressure sensor with the current barometric pressure, and must be done with the EPC/EPCD pressure sensor open to atmosphere:

Tare gauge pressure: `[unit ID]p↵`

Example: `ap↵`

! *Warning: Do not send tare commands on absolute pressure EPC/EPCD*

Collecting Pressure Data

Collect live data by typing the `[unit ID]↵` command or by setting your controller to streaming. Each line of data for live measurements appears in the format below, but Unit ID is not present in streaming mode.

The data frame on the screen represents the current measurements in the device in the units shown on the display. By default, pressure controllers are configured to output three columns of data.

A	+50.42	50.42
Unit ID	Pressure	Setpoint

Single spaces separate each parameter, and each value is displayed in the chosen device engineering units. You can query the engineering units of the serial data frame by typing:

Query live data info: `[unit ID]??d*↵`

Example: `a??d*↵`
(returns the data frame descriptions)

Additional columns, including status codes, may be present to the right of the last column.

Commanding a New Setpoint

Before attempting to send setpoints to your flow controller serially, confirm that its setpoint source is set to serial by checking register 20.

Read Register 20: `[unit ID]r20↵`

Example: `ar20↵`

For an EPC set to control forward pressure or an EPCD, if the value in register 20 is less than 16384, it's already set up to receive setpoints serially. If not, subtract 16384 to current value using the subtract command below.

For an EPC set to back pressure control, if the value in register 20 is less than 49152, it's already set up to receive setpoints serially. If not, subtract 16384 to current value using the subtract command.

Subtract from Register 20: `[unit ID]w20=-16384↵`

Example: `aw20=-16384↵`

There are two ways to command a new setpoint over a serial connection, as described below. In either of these methods, the data frame returns the new setpoint value when it has been accepted as a valid setpoint.

Sending Setpoints as Floating Point Numbers

This is how to send the desired setpoint value as a floating point number in the engineering units selected:

New setpoint: `[unit ID]s[floating point number setpoint]↵`

Example: `as5.44↵` (setpoint of +5.44 inH₂O_G)

When using a pressure controller with a negative pressure range or a bidirectional range, negative sent points are sent by adding the minus sign.

New setpoint: `[unit ID]s[floating point number setpoint]↵`

Example: `as-5.44↵` (setpoint of -5.44 inH₂O_G)

Sending Setpoints as Integers

In this method, your controller's full scale range (FS) is represented by a value of 64000, and a zero setpoint is represented by 0. To calculate your intended setpoint, use the following formula:

$$\text{Integer value} = 64000 \times [\text{desired setpoint}] / [\text{device FS}]$$

Example 1: A desired setpoint of +5.44 inH₂O_G on a 10-inH₂O_G pressure controller is calculated as $64000 \times 5.44 / 10.00 = 32704$. The command to assign the setpoint based on this integer value is:

New setpoint: [unit ID][setpoint as integer where 64000 is FS]↵

Example: **a32704**↵ (setpoint of 5.44 inH₂O_G)

Example 2: When using a bidirectional pressure controller, 0 represents -100% of full scale, 32000 represents 0, and 64000 represents +100% of full scale. Use the formula below to calculate the integer value.

$$\text{Integer value} = 64000 \times [\text{desired setpoint} + \text{FS}] / [\text{device FS}]$$

A desired setpoint of +5.44 inH₂O_G on a 10-inH₂O_G pressure controller is calculated as $64000 \times [5.44 + 10] / 10.00 = 9882$. The command to assign the setpoint based on this integer value is:

New setpoint: [unit ID][setpoint as integer where 64000 is FS]↵

Example: **a9882**↵ (setpoint of 5.44 inH₂O_G)

Example 3: A setpoint of -5.44 inH₂O_G on the same bidirectional controller is calculated as:

$$\text{Integer value} = 64000 \times (-5.44 + 10) / 10 = 29184$$

PID Tuning:

Your flow controller uses a closed-loop algorithm to determine how to actuate its valve(s) in order to achieve the commanded setpoint. We have tuned these settings for your specific operating conditions, but changes to your process sometimes require on-site adjustments to maintain optimal control performance. If you encounter issues with control stability, oscillation, or speed of response, fine-tuning your closed loop control may help.

Changing Gain Values

The only way to adjust The P, D, and I gains on an EPC or EPCD device is by adjusting registers 21, 22, and 23, respectively.

For more information on reading and adjusting 16-Bit registers, as well as definitions of the functionality of registers on the EPC or EPCD device please download the Alicat Serial Primer at: Alicat.com/drivers

Tuning the PD/PDF control algorithm

The EPC controller's default control algorithm (PD) employs pseudo-derivative feedback (PDF) control, which uses two editable variables:

- The larger the D gain, the slower the controller will correct errors between the commanded setpoint and the measured process value. This is equivalent to the P variable in common PDF controllers.
- The larger the P gain, the faster the controller will correct for offsets based on the size of the errors and the amount of time they have occurred. This is equivalent to the I variable in common PDF controllers.



Note: The D and P variables in the PD/PDF control algorithm are more typically referred to as P and I, respectively, in PDF

Tuning the PD²I control algorithm

The EPCD controller's PD²I control algorithm is used to provide faster response, and high-performance swapping of the operation of the inlet and exhaust valve. This algorithm uses typical PI terms and adds a squared D term:

- The larger the **P** gain, the more aggressively the controller will correct errors between the commanded setpoint and the measured value.
- The larger the **I** gain, the faster the controller will correct for offsets based on the size of the errors and the amount of time they have occurred.
- The larger the **D** gain, the faster the controller will predict needed future corrections based on the current rate of change in the system. This often results in slowing the system down to minimize overshoot and oscillations.



Warning: EPCDs are only intended for use with PD²I tuning and may experience significant performance issues if switched to PD/PDF.

Troubleshooting valve performance with PID tuning

The following issues can often be resolved by adjusting the PID gain values for your flow controller.

Fast oscillation around the setpoint

- PD: Reduce the P gain in decrements of 10%
- PD²I: Increase the P gain in increments of 10%, and then adjust the I gain to fine-tune.

Overshot setpoint

- PD: Reduce the P gain in decrements of 10%.
- PD²I: If D is not 0, increase the P gain in increments of 10%.

Delayed or unattained setpoint

- PD: Increase the P gain in increments of 10%, and then decrease the D gain by small amounts to fine-tune.
- PD²I: Increase the P gain in increments of 10%, and then increase the I gain to fine-tune.



Note: Valve tuning can be complex. Please give us a call, and we'll be happy to guide you through the process. Or, visit alicat.com/pid for more detailed instructions

Quick Command Guide



Note: Serial commands are not case-sensitive. For simplicity, we assume that the unit ID of the flow controller when not streaming is **a** in the listing that follows.

- Change unit ID: a@[desired unit ID]↵
- Tare pressure: ap↵
- Poll the live data frame: a↵
- Begin streaming data: a@=@↵
- Stop streaming data: @@=[desired unit ID]↵
- Set streaming interval: aw91=[number of milliseconds]↵
- New setpoint: as[setpoint as floating point #]↵
- New setpoint: a[setpoint as integer where 64000 is full scale]↵
- Hold valve(s) at current position: ahp↵
- Hold valve(s) closed: ahc↵
- Exhaust (EPCD only): ae↵
- Cancel valve hold: ac↵
- Query live data info: a??d*↵
- Manufacturer info: a??m*↵
- Firmware version: a??m9↵
- Write P Gain: aw21=[desired gain value]↵
- Write D Gain: aw22=[desired gain value]↵
- Write I Gain: aw23=[desired gain value]↵

Additional information can be found on our online Serial Primer document, at: Alicat.com/drivers

If you have need of more advanced serial communication commands, please contact support ([page 2](#)).

Maintenance

Cleaning

This device requires minimal maintenance. If necessary, the outside of the device can be cleaned with a soft dry cloth. Avoid excess moisture or solvents.

The single most important thing that affects the life and accuracy of these devices is the quality of the gas being measured. The instruments are designed to measure clean, dry, non-corrosive gases.

Recalibration

The EPC device is an OEM product calibrated to NIST traceable standards at the time of manufacture. As an OEM device there is not a factory recommended periodic recalibration cycle. Recalibration can be requested at the user's discretion/requirement. A recalibration can be requested with your serial number at alicat.com/service.

For repair, recalibration, or recycling of this product contact us ([page 2](#)).

Technical Specifications and Dimensional Drawings

Please visit alicat.com/specs to find complete operating specifications and dimensional drawings.