

SDO Single Use Precision Back Pressure Regulator

REGULATOR USE AND STARTUP

WARNING:

Make sure that you have read and understand these directions before using, installing, or maintaining the Equilbar pressure regulator. Take steps to ensure this instruction manual reaches the operator of this regulator and stays with the regulator throughout its lifetime. Use, installation, operation, and maintenance of all pressurized products including this regulator must be performed by personnel who are properly trained and qualified through experience or specific training.

Failure to properly observe the instructions contained in this document may result in, but is not limited to:

- Serious personal injury or death
- Unconstrained release of the pressurized media
- Permanent damage to the pressure regulator and/or permanent damage to connected equipment

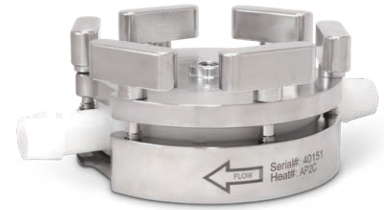

SDO single use back pressure valve

BACKGROUND

Equilbar® SDO Single Use regulators are precision back pressure regulators (BPRs). The USP Class VI polymer body and diaphragms are disposable and are inserted into a reusable stainless steel cradle assembly with wing nut closure for quick and easy assembly.

This BPR controls the fluid pressure at its inlet port by allowing excess flow to vent from the system through the outlet port. The flow direction is from inlet to outlet. See barb markings for I/O.

The Equilbar SDO is pilot operated. The pressure setpoint is determined by the pilot pressure that is applied to the reference port, also known as pilot or dome port. The BPR will control the pressure on its inlet port in a precise 1 to 1 relationship with the pressure applied to the pilot port. The pilot pressure may be applied with a mechanical knob adjusted regulator or with an electronic pressure regulator (see Fig. 1).

The Equilbar BPR uses a flexible membrane diaphragm to both sense the pressure and to provide a direct seal against the orifices in the regulator body. The pilot pressure is applied to one side of the diaphragm. The Inlet "I" port pressure is sensed on the other side of the diaphragm. When the inlet pressure is greater than the Inlet pressure, the diaphragm is pushed firmly against the orifices to form a seal and the regulator is effectively closed. When the inlet pressure builds and just equals the pilot pressure, the closing forces are overcome, the diaphragm lifts and media can begin to pass from the Inlet to the Outlet port. When sufficient media has passed through the regulator, the Inlet pressure will be reduced slightly, and the diaphragm is allowed to seal against the orifices again. In normal operation, equilibrium is achieved and the diaphragm modulates in a position where just enough flow is allowed out of the regulator in order to maintain a steady pressure on the inlet port (see Fig. 2).

Typical Circuits:

An SDO back pressure regulator can be used to control the pressure across a membrane filter. In the example circuit shown in Fig. 3, an Equilbar SDO BPR is installed in the retentate lines of a tangential flow filtration (TFF) process. Using an electronic pilot regulator (E/P), a setpoint is established to the dome of the SDO valve to deliver the desired transmembrane pressure (TMP). The SDO regulator is able to adjust quickly to changes in upstream pressure or flow in order to maintain stable target TMP process control.

Equilbar has trained engineers who can work with you to suggest a regulator design for your specific application. These suggestions are recommendations only and are dependent on complete and accurate information from the end user about the application.

It is the ultimate responsibility of the user to determine the compatibility of the media with the materials of construction of the back pressure regulator and with the pilot gas in use.

Fig. 1 HOW EQUILBAR TECHNOLOGY WORKS

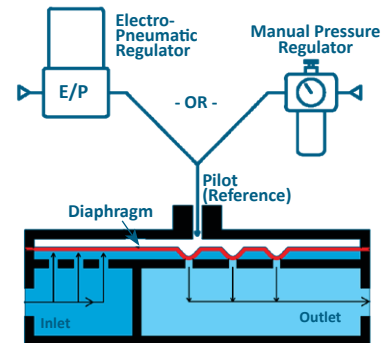

Fig. 2 PRESSURE BALANCE DIAGRAM

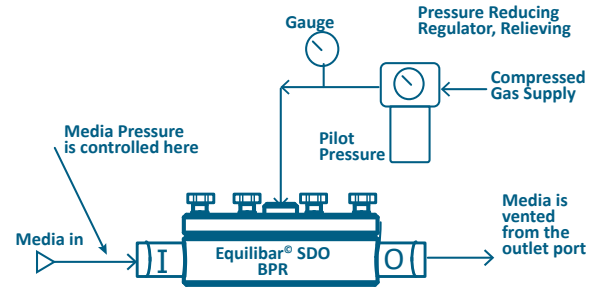
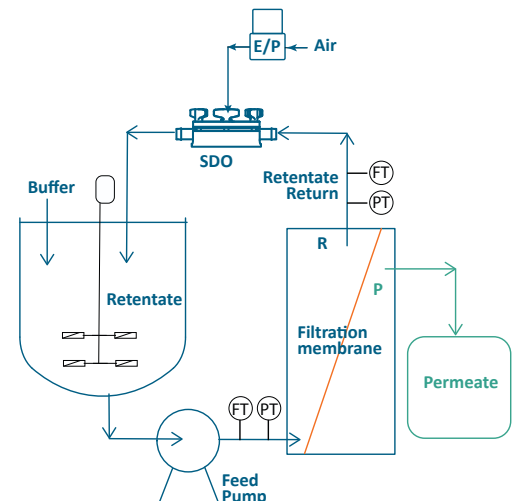

Fig. 3 TANGENTIAL FLOW FILTRATION



SDO Single Use Precision Back Pressure Regulator

PREPARING FOR INSTALLATION

- Inspect the Equilibar SDO for any damage.
- Call or email Equilibar if you have any questions, concerns, or need a new copy of these instructions. +1(828)-650-6590; inquiry@equilibar.com
- Take precautions to prevent injury to personnel in the event of a diaphragm failure or external leak. Sensitive fluid controls can experience internal or external leaks. See standard terms and conditions for important limitations of liability notes.
- The Equilibar BPR is not a “Safety Accessory” as defined by the Pressure Equipment Directive 2014/68/EU. Be sure to install appropriate overpressure protection devices such as safety relief valves or rupture discs to protect the system and the BPR from exceeding the maximum allowable working pressures. These safety devices must meet applicable law, codes, regulations, and standards for your jurisdiction.
- Equilibar SDO disposable polymer bodies are prepared and packaged in an ISO class 7 clean room and shipped in hermetically sealed plastic bags ready for sterilization.
- **Note:** The SDO product series *is not sold as a sterile device*. It is gamma sterilizable up to 50 kGy.
- Inlet and Outlet ports are labeled with a pronounced “I” and “O” molded into the hose barbs. Ensure that flow goes from the inlet “I” port to the outlet “O” port.
- The I and O will align with the FLOW arrow lasered on the stainless steel cradle.
- The inlet port will be connected to the point in the system where it is desirable to maintain or control the pressure of the media. The best pressure control will be seen if the plumbing to the BPR inlet port is as short and as large as practical to minimize the amount of pressure drop in the plumbing.
- To help ensure proper orientation of the SDO body in the cradle, there is a keyway in the stainless steel cradle that matches to a key form in the SDO polymer body. This means the body can only be oriented in one way.

When properly oriented, the arrow lasered on the stainless steel cradle indicates direction of flow. See images below.

- **Note:** If you have an older model lower cradle, it will not have these orientation features. **Please contact Equilibar for assistance.**
- System media will be vented out the BPR outlet port. Be sure that the media is vented to a safe environment, away from employees, and in accordance with applicable laws in your jurisdiction.
- Any bolt, screw, or connector that is threaded into a stainless steel cradle assembly should have some small amount of lubricant to prevent thread galling. Thread galling is usually permanent and causes the regulator to be scrapped. The Equilibar factory applies USP Class VI certified DuPont Krytox to bolt thread connections that are not wetted by the process fluid.

INFORMATION ABOUT THE PILOT REGULATOR

- The pilot pressure supply should be an inert compressible gas. Incompressible media such as liquids do not make effective pilot pressures because they do not allow the BPR diaphragm to adjust quickly. Make sure the pilot media is compatible with the media flowing through the BPR.
- The controlled pressure is a near exact 1:1 relationship to the pilot pressure. Installing a pressure gauge in the pilot port may offer advantages over installing a gauge in the Inlet “I” port. The inert pilot media can be read with a less expensive gauge and the pilot pressure may be set even when there is no system media actively flowing.
- The BPR is designed to have maximum pilot pressure applied before there is pressurized media at the inlet port. But it is advised to remove pilot pressure when device is not in use.



SDO polymer body with key for orientation



SDO stainless steel cradle with FLOW direction arrow

PATENT INFORMATION

Equilibar regulators are subject to the patents listed at www.equilibar.com/support/patents

SDO Single Use Precision Back Pressure Regulator

CRADLE MOUNTING INSTRUCTIONS

1. The SDO cradle is shipped with a protective insert which will need to be removed prior to use.
2. The cradle assembly should be mounted in a location where the **reference cap is easily accessible**. The reference cap will need to be removed each time the single use valve body is replaced.
3. Cradle mounting patterns are shown in Fig. A and B. SDO sizes 1,2 and 3 share a mounting pattern. SDO sizes 4,6 and 8 share another mounting pattern for easy change-out if desired.
4. Before mounting, ensure the cradle is properly positioned so that the process inlet and outlet are oriented with the **flow direction arrow** on the cradle (see image below).
5. Connect pilot pressure line from the pilot regulator to the reference port of the cradle reference cap (see Fig. C).

MOUNTING PATTERNS

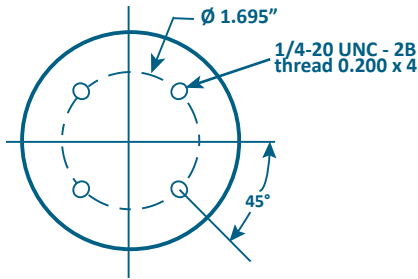

Fig A: Mounting pattern SDO1,2 and 3



Note FLOW direction when mounting

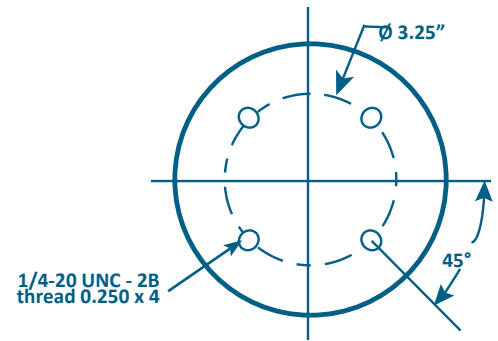

Fig B: Mounting pattern SDO4,6 and 8

INSTALLING / REPLACING THE SDO VALVE BODY

1. Before changing the SDO valve body, be sure the system is shut down, the pilot pressure is removed, and no fluid is running through the system.
2. Loosen the wing screws from bottom cradle and remove the reference cap. Keep wing screws threaded to reference cap.
3. Remove and dispose of the old SDO valve body per local disposal instructions and regulations. Take care not to remove the bottom cradle gasket.
4. To ensure proper valve orientation, insert the new SDO body into the cradle by matching the keyway and key (see p. 2). Inlet and Outlet ports are labeled with a pronounced "I" and "O" molded into the hose barbs and will match the flow arrow on the cradle with correct keyway installation.
5. Place the stainless steel reference cap onto the body and bottom cradle, aligning reference cap flow arrow and I/O markings with flow direction of the process. (See Fig. D) Align the wing screws with the holes in the bottom cradle taking care not to damage diaphragm material with wing screws.

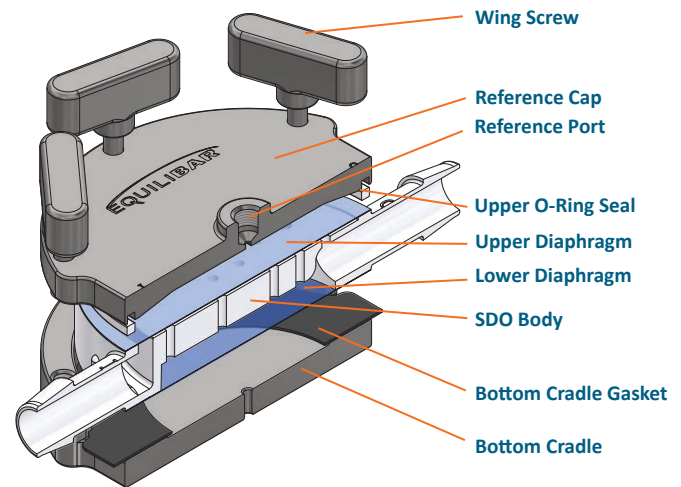

Fig C: Exploded view of SDO



Fig D: SDO reference cap with flow arrow and I/O markings to assist with proper orientation

CONTINUES ON NEXT PAGE

SDO Single Use Precision Back Pressure Regulator

INSTALLING THE SDO VALVE BODY (CONTINUED)

- Tighten screws to the torque specification in **Table 1** below using a criss-cross or star pattern similar to that shown in Figures D, E and F. Tightening may be done by hand. Make sure the cap is flat while tightening. **Note:** fluid may leak if wing nuts are not completely tightened, and over-tightening may lead to valve failure.
- Valve is ready to use. Equilibar recommends that reference pressure be applied just prior to starting the process, and depressurized when not in use.
- Exercise caution when reducing the pilot pressure during operation. When pilot pressure is reduced, flow is increased through the BPR as system pressure is relieved. A quick reduction in pilot pressure can result in extremely rapid release of media through the outlet port. It is recommended to reduce the pilot pressure as slowly as practical.

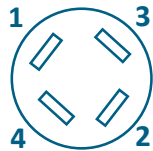

Fig D - SDO1, 2, 3

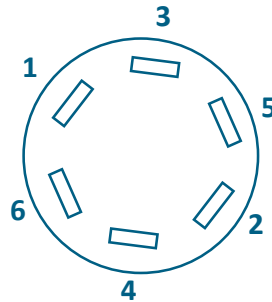

Fig E - SDO4, 6

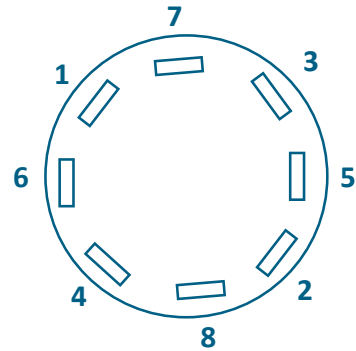

Fig F - SDO8

TORQUE SPECIFICATIONS

| MODEL SIZE | TORQUE RANGE | FIGURE |
|-------------|------------------------------|--------|
| SDO1 - 1/8" | 5 - 10 in-lb (0.6 - 1.7 Nm) | D |
| SDO2 - 1/4" | 5 - 15 in-lb (0.6 - 1.7 Nm) | D |
| SDO3 - 3/8" | 5 - 25 in-lb (0.6 - 2.8 Nm) | D |
| SDO4 - 1/2" | 10 - 25 in-lb (1.1 - 2.8 Nm) | E |
| SDO6 - 3/4" | 10 - 25 in-lb (1.1 - 2.8 Nm) | E |
| SDO8 - 1" | 10 - 25 in-lb (1.1 - 2.8 Nm) | F |

Table 1: Torque Settings BY MODEL SIZE

Note: Models have four (4), six (6), or eight (8) wing screws. Use appropriate torque pattern for the model you have: either criss-cross (4 screw) or star (6 or 8 screws).

TROUBLESHOOTING

| PROBLEM | POSSIBLE SOLUTIONS |
|------------------------------------|---|
| Maximum flow is reduced | Replace valve |
| External leak around diaphragm | Check for loose bolts or punctured diaphragm |
| Chatter on the downstream tubing | Contact Equilibar for additional assistance |
| Air in process | Check for ruptured diaphragm |
| Fluid out of the reference port | Check for ruptured diaphragm |
| Damage to cradle gasket (tear etc) | Contact Equilibar to order replacement |

CONTACT EQUILIBAR



Contact Equilibar for regulatory compliance / certification details or for any questions

email: singleuseteam@equilibar.com

phone: 828-650-6590

SDO Single Use Precision Back Pressure Regulator



SYSTEM HAZARD ANALYSIS

Both normal operation as well as possible failure modes and foreseeable misuse must be accounted for in the design of the system which interacts with and connects to the Equilibar back pressure regulator (BPR). It is the responsibility of the end user to account for these hazards. **Please read all of the following safety and hazard precautions before installing or operating any equipment.**

- a. The BPR is not certified as or marketed as a pressure vessel safety relief valve. The BPR is a precision control valve. Guarding against overpressure must be achieved with devices designed and marketed as such.
- b. Sensitive diaphragms and external seals can leak. It is the responsibility of the end user to use this product in a way that prevents injury to personnel should leakage occur. See Standard Terms and Conditions for important Limitation of Liability notes.
- c. Diaphragms may fail in the open or closed position. Proper safety precautions should be taken for either failure mode.
- d. If the internal diaphragm ruptures or leaks, the pilot fluid can be introduced into the process fluid or vice versa. Make sure that the fluids are compatible and not hazardous when mixed.
- e. Most auxiliary pressure regulators used to provide pilot pressure to the BPR are of the self-relieving design. Guard against the process fluid relieving out the pilot regulator if the BPR diaphragm fails.
 - i. One method to accomplish this is to set the pilot pressure into a static volume chamber that is sealed with an ON/OFF valve after the pressure is set to the desired value.
 - ii. Another method is to feed the pilot pressure from the pilot regulator through a check valve to the BPR. In order to reduce the pilot pressure, a bleed from the pilot port to a safe location must be employed. In many cases this bleed can be made to the output of the BPR.
- f. If an electronic pressure regulator is used for a pilot regulator, then special consideration must be made. In addition to reviewing the prospect of having the process media coming in contact with and venting out of the electronic pressure regulator, the possibility of ignition of the media by the electronic pressure regulator must be examined. It is the user's responsibility to determine if a hazardous area classification exists and to make sure that the electronic pressure regulator employed meets or exceeds the requirements of intrinsic safety for that area.
- g. If the internal diaphragm ruptures or leaks, the result is often that the BPR will fail into a closed position. This results in a blocked pipe with no path for the fluid to escape through the BPR. Over pressurization of the upstream can occur. Steps must be taken to ensure that the upstream piping is made sufficiently strong to withstand this or is guarded by an overpressure relief device.
- h. Make sure the process pressure to be controlled is connected to the BPR Inlet port. Process fluid flow is from the Inlet to the Outlet. If the BPR is connected in reverse, it will still operate but it will give poor control and can result in excess pressures. See orientation instructions on pages 2 and 3.
- i. Observe the maximum temperature and pressure ratings on the BPR label. Take steps to ensure these values cannot be exceeded. Where necessary to protect equipment, a suitable type of safety overpressure relief valve must be connected in parallel to the BPR. The overpressure relief valve must be rated to prevent the pressure or temperature from exceeding the BPR maximums as listed on the BPR label. In some installations a rupture disc may be substituted for the safety relief valve.
- j. If the discharge piping on the BPR Outlet port becomes blocked, the BPR will open and fill the discharge piping to the same pressure as the maximum pressure in the system. The discharge piping must be rated to contain this pressure or have a safety relief valve to limit this pressure at or below the safe pressure of the discharge piping.
- k. Do not use the BPR as a structural member. All piping and plumbing connections to the BPR should be adequately supported. The BPR series is available with a mounting bracket to facilitate the installation.
- l. The BPR has been carefully designed by skilled engineers to provide proper safety ratios and adequate pressure regulation. Do not attempt to modify the BPR in any way, including adding or enlarging orifices or ports or replacing wing nuts.
- m. Never perform maintenance or inspections on a system when pressurized fluids are present. De-pressurize the system before performing this work. De-pressurize inlet pressure before reference pressure, otherwise a quick drop in reference pressure can lead to a violent exhaust of the upstream pressure through the regulator.

Equilibar's quality system is
ISO 9001:2015 certified.