

**RHEONIK.**



# **RHM Coriolis Sensor User Manual RHM015 – RHM20**



Rheonik Messtechnik GmbH  
Rudolf-Diesel-Straße 5  
D-85235 Odelzhausen  
Germany

Tel + 49 (0)8134 9341-0  
info@rheonik.com

LEARN  
MORE



Document No.: 8.2.1.10  
Version 1.37  
March 2025

# **RHM 015 - 20**

# **Coriolis Sensor**

User Manual

**RHEONIK.**



---

## Table of Contents

<b>1</b>	<b>General Information</b>	<b>7</b>
1.1	Intended use	7
1.2	Important Instructions and Safety Information for Operating Coriolis Flow Meters	7
1.3	Manufacturer's Liability	8
1.4	Additional Resources	8
<b>2</b>	<b>Introduction to Rheonik Coriolis Flow Meters</b>	<b>9</b>
2.1	RHMxxx Sensor	9
2.2	RHExx Transmitter	9
2.3	Product description RHM Sensor	9
2.4	Type Label	10
<b>3</b>	<b>Mechanical Installation</b>	<b>11</b>
3.1	Storage, Handling and Transportation	11
3.1.1	Lifting	11
3.2	Filters and Strainers	12
3.3	Temperature	12
3.4	Zeroing Procedure and Isolation Valves	12
3.5	Upstream/Downstream Straight Run Requirements	13
3.6	Accessibility	13
3.7	Vibration	13
3.8	Cross Talk	14
3.9	Magnetic Interference	14
3.10	Pipe Alignment	14
3.11	Flow Direction	14
3.12	Horizontal Pipe Mounting	14
3.13	Vertical Pipe Installation	16
3.14	Critical Installations	17
3.1	Liquids with low Vapor Pressure	17
<b>4</b>	<b>Electrical Connection to RHE</b>	<b>17</b>
<b>5</b>	<b>Service and Maintenance</b>	<b>18</b>
5.1	Maintenance and Calibration	18
5.2	Troubleshooting	18
5.3	Service	19

---

5.4	WEEE and RoHS .....	19
<b>6</b>	<b>Ordering Code .....</b>	<b>20</b>
<b>Appendix A</b>	<b>Ex-Safety Instructions.....</b>	<b>21</b>
A.1	Safety instructions for the installation in a hazardous area: .....	21
A.2	System Description: .....	22
A.3	Electrical Safety Limits.....	22
A.4	Thermal Safety Limits .....	23
A.5	Grounding .....	27
A.6	Electrical connection to RHE.....	27
A.7	Ordering Code.....	29
A.8	Technical Data .....	30
A.9	Service and repair .....	30
A.10	Contact address .....	30

---

## 1 General Information

Thank you for choosing a Rheonik Coriolis Flow Meter. Each meter is designed to give many years of service in one of a wide variety of applications across many industries.

Prior to delivery, the meter was carefully calibrated, and the entire sensor subjected to an overpressure test at 1.5 times the maximum operating pressure limit. Manufacturing records are meticulously maintained for each sensor to assist in any future support request received.

This manual is one of several available packed with valuable information on how to get the best performance out of your Rheonik flow meter. If you cannot find an answer in the manual set to any question you might have related to start up, operation or support of this product, please contact your local sales/support agent or Rheonik Support for immediate assistance.

### 1.1 Intended use



Rheonik Coriolis mass flow measuring instruments consisting of a sensor (RHM), a transmitter (RHE), and in some cases, an interconnecting cable, are intended for measuring liquids and gases.

The operator must ensure that the instrument is only used in a way that complies with limitations and certifications listed on the instrument type plates. These limitations/certifications include, but are not limited to:

- Pressure and temperature ranges
- Approval limits (e.g., explosion protection, pressure equipment directive)
- Suitability of the materials of construction in contact with the process

The instrument must be installed, operated, and maintained in accordance with the manufacturer's instructions and guidelines.

The instrument must not be modified or altered in any way that has not been approved by the manufacturer or certification body.

Regular inspections and preventive maintenance should be carried out to ensure ongoing safety and performance.

Use not in accordance with the intended purpose may impair and/or endanger safety.

### 1.2 Important Instructions and Safety Information for Operating Coriolis Flow Meters



Rheonik flowmeters are made for a wide variety of applications and in compliance with many international standards. Maximum operating limits (temperature, pressure) for each RHM flow sensor are stated on the permanently attached serial number plate and must not be exceeded.

Where flowmeters are operated at elevated temperatures, thermal insulation around the sensor should be provided to ensure that the entire flowmeter is kept at or very near the operating temperature of the process.

When using flow meters in or near piston pump outlets, ensure pressure peaks in the process line do not exceed the flow sensor maximum pressure limit.

---

Meters installed in any process with an abrasive fluid may be subject to internal wear with a subsequent reduction of tubing wall thickness. This abrasion may reduce the safe maximum operating pressure of the meter. In applications where internal wear is a possibility, we recommend instigating an NDT program to monitor the meter condition. Please contact Rheonik for assistance with determining a procedure for such a program.

The process wetted material(s) within the flow meter are stated on each meters' serial number plate. It is the sole responsibility of the end user to ensure that these material(s) are suitable for use with the process the meter is applied to. In applications where internal corrosion is a possibility, we recommend instigating an NDT program to monitor the meter condition. Please contact Rheonik for assistance with determining a procedure for such a program.

Flow meters installed in processes in the pharmaceutical or food and beverage industries should, where appropriate, be fully cleaned before being put into service.



Caution, the surface of a meter may be hot.

### **1.3 Manufacturer's Liability**



Rheonik assumes no liability for loss and/or consequential damages stemming from the use of this product in life-preserving systems in the medical, motor vehicle, aircraft, water craft or mining industries.

Rheonik accepts no liability for loss or damage resulting from the improper use of any of its products.

Rheonik assumes no liability for the loss of production and/or consequential damage from the use of this product unless such liability has been expressly and contractually agreed.

Rheonik provides a standard one year from shipment warranty on all products for workmanship and materials. Performance of this warranty will be at the Rheonik manufacturing facility.

Rheonik assumes no liability for determining the suitability of its products in any specific application. This is the sole responsibility of the end user.

### **1.4 Additional Resources**

This manual is intended to aid in the installation and startup of a Rheonik Coriolis mass flow sensor supplied as part of a mass flow meter system. For information related to installation and startup of its associated RHE transmitter (and other resources), please download the relevant manual from the Rheonik website:

[www.rheonik.com](http://www.rheonik.com)

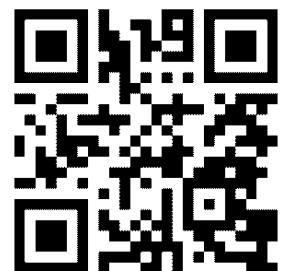

---

## 2 Introduction to Rheonik Coriolis Flow Meters

A complete flowmeter system typically consists of a:

- RHMxxx Sensor
- RHExx Transmitter
- Interconnection cable

### 2.1 RHMxxx Sensor

Inside an RHM sensor, there are precision tubes energized by an electromagnetic drive system controlled by the attached RHExx transmitter. These tubes vibrate at their natural frequency.

When a fluid (liquid or gas) flows through these vibrating tubes, they are subjected to non-symmetrical deflection, the degree of which is determined by the mass of the fluid passing through. This deflection is detected electronically by two sensors within the flow meter body. High-precision electronics in the transmitter process the sensor signals and calculate a time delta between them. This time delta is proportional to the mass flow rate.

RHMxxx sensors are intrinsically safe and can be certified for use in hazardous areas when connected to a suitably certified transmitter.

Standard flow meter dimensional information can be found in each of the RHMxxx data sheets. Data sheets or exact drawings for customized products can be obtained through your local sales/support agent or from Rheonik.

### 2.2 RHExx Transmitter

The transmitter provides the drive energy for maintaining tube vibration within the sensor, processes and evaluates of the measured signals and calculates mass flow along with other parameters.

When used with an RHMxxx sensor in a hazardous area, the RHE is equipped with the necessary safety barriers as required by local regulations.

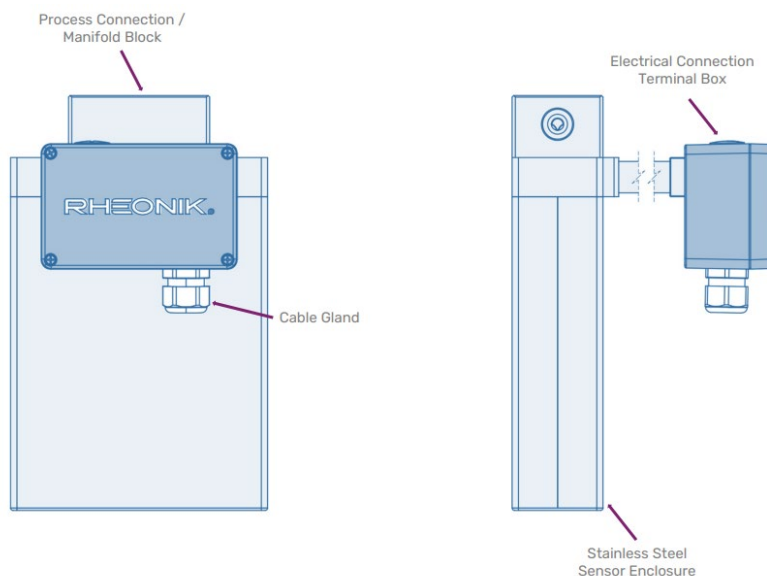

A detailed description of transmitter features is available in each of the RHExx data sheets.

### 2.3 Product description RHM Sensor



## 2.4 Type Label

The type label and its contents depend on the respective version and approval according to ATEX/IECEx and/or CSA. The example shows a version with dual approval.

<b>RHEONIK.</b> Rheonik Messtechnik GmbH Germany, 85235 Odelzhausen, Rudolf-Diesel-Straße 5		Class I, Zone 0, AEx ia IIC T6...T1 Ga		Ex ia IIC T6...T1 Ga		 C US 220495				
		Class I, Div. 1, Groups A, B, C and D T6...T1		CSA 18CA70138578						
Coriolis Flow Sensor RHM 04 GNT (p) - G ½"		<b>A</b>								
Order Code: M04SN1P1PM035G1JM-NN-U0		<b>B</b>		T6	T5	T4	T3	T2	T1	
Ser. No.:	RHM-123456	<b>C</b>		Min Ambient Temp.	-20°C	-20°C	-20°C	-20°C	-20°C	
TAG No.:	TAG Number	<b>D</b>		Min Process Temp.	-20°C	-20°C	-20°C	-20°C	-20°C	
Product Group PRESSURE ACCESSORIES				Max Ambient Temp.	65°C	80°C	80°C	80°C	80°C	
Nom. Flow [kg/min]:	12	<b>E</b>		Max Process Temp.	65°C	80°C	115°C	120°C	120°C	
Nom. Diam. [mm]:	8	<b>F</b>								
PS (Tc/Tmax) [barg]:	177 / 156	<b>G</b>		Intrinsically Safe Circuits	Pins	UI (V)	II (mA)	PI (mW)	CI (nF)	LI (mH)
TS (Tmin/Tc/Tmax) [°C]:	-20 / 50 / 120	<b>H</b>								
Prot. Rating:	IP66 / Type 4X	<b>I</b>		Drive Circuits	1-2	9.3	144	335	10	1.5
Connection:	G ½" female thread	<b>J</b>		Pickup Circuits	6-7 9-8	7.4	29	54	10	4.5
Wetted Parts:	<b>K</b> 1.4435 / SS 316L, 1.4404 / SS 316L, FKM/FPM			Temperature Sensor	3-4 5-4	7.4	58	107	10	0.1
Manufacturing Date:	2024	Made in Germany								
 0036 0044 Flashing Liquids not allowed		Ex II 1G Ex ia IIC T6...T1 Ga		BVS 17 ATEX E 074 X						
		Ex ia IIC T6...T1 Ga		IECEx BVS 17.0063X						

- 1 Company name and full address of the manufacturer
- 2 Hazardous area classifications and certification numbers
- 3 CE for conformity
- 4 Table with safety limits for intrinsically safe circuits
- A Product designation
- B Model code
- C Serial number
- D Customer-specific tag number RHM Coriolis sensor
- E Nominal Flow ( $Q_{nom}$ )
- F Nominal Diameter (Measurement Loops)
- G Maximum operating pressure depending on temperature
- H Maximum permissible operating temperature
- I Protection rating
- J Connection
- K Material of wetted parts incl. gasket material (if applicable)

---

### 3 Mechanical Installation

Proper meter performance depends upon good installation. This chapter details best practices for installing a meter in different types of applications.

#### 3.1 Storage, Handling and Transportation

Upon receipt of a meter shipment:

- Inspect the package thoroughly for damage. If there is evidence of damage, please notify the carrier and your local sales/support agent immediately.
- Review the packing list and check that all ordered components have been received.
- Check the serial number plate(s) to ensure that the components delivered are according to the purchase order.

##### 3.1.1 Lifting

Heavy sensors require additional consideration when lifting them into their installation position:

- Professional equipment for handling heavy sensors should be used.
- Lift sensors as shown in Figure 1.
- Do not lift a sensor by its electrical junction box or purge fittings.

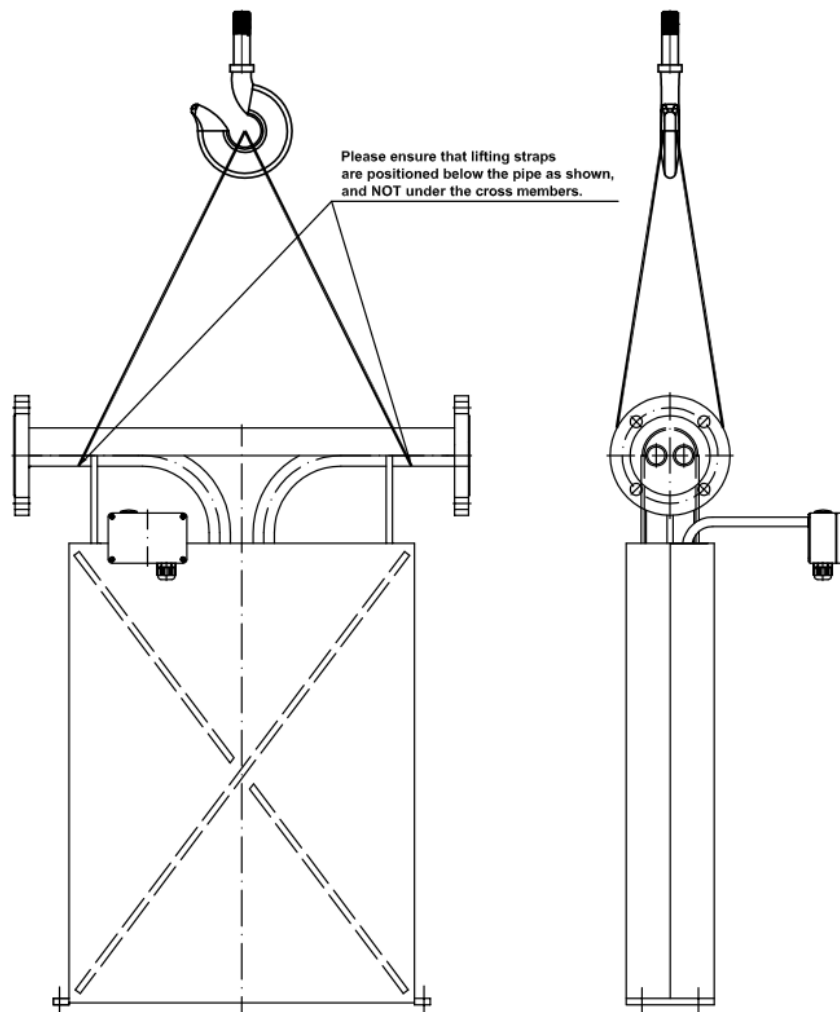

Figure 1: Lifting a heavy meter

---

After the sensor has been removed from its packaging, check to ensure that all accessories and documentation have also been removed. The packaging should be kept and stored for possible future shipment. Flow meters should be stored in the following conditions:

- Store in a dry and dust-free location.
- Avoid direct exposure to solar radiation.
- Store in original packing.
- Store in temperatures between -20°C and +70°C.

### **3.2 Filters and Strainers**

For liquid measurement applications that have solid particles with a diameter of 0.25 times the inside diameter for the measuring tubes, a filter/strainer must be installed upstream from the flow meter to reduce the risk of blockage.

A filter must be installed for gas measurement applications with abrasive particles in the stream (e.g. rust particles) in order to avoid damage (abrasion) to internal measurement tubes.

### **3.3 Temperature**

Do not install the meter in an application that will exceed its maximum temperature rating (see serial number plate for temperature limit). The flow meter should be installed such that it is kept at the same temperature while in operation.



Rapid temperature changes should be avoided whenever possible. Rapid temperature changes may impact the performance and lifetime of the sensor.

Temperature change to a sensor should be at a rate of no more than 1°C per second.

Temperature changes while in operation should be minimized by the use of insulation and/or heat tracing where applicable.

### **3.4 Zeroing Procedure and Isolation Valves**

Like all Coriolis instruments, the meter may require zeroing from time to time to remove any offset in the measured flow rate.

Zeroing of the meter should be carried out:

- When an RHM flow sensor and/or RHE transmitter has been newly installed.
- Before field or laboratory calibration of the meter.
- During routine maintenance of the meter.

Please refer to the RHE Installation and Startup Guide for zeroing instructions.

For the best measurement performance, the meter should be zeroed under full operating pressure and temperature. A shut off valve should be installed downstream of the meter to facilitate zeroing. It is highly recommended to install a valve upstream of the meter as well to prevent convection flow that might affect the zeroing procedure. Only tight-closing, high-quality valves should be used. In the majority of cases, relying upon simply switching off a pump will not be sufficient.

---

Figure 2 shows the recommended installation of an RHM sensor with valves to facilitate meter zeroing.

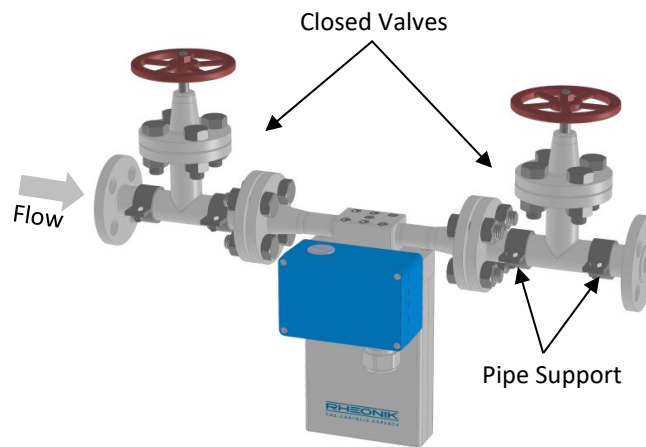

Figure 2: Zeroing with closed valves

### 3.5 Upstream/Downstream Straight Run Requirements

No upstream/downstream straight run is required for sensor models RHM015 – RHM20 with a manifold or serial (single path) seal-less construction type. For seal-less, parallel construction type sensors, straight pipe sections of 5-10 pipe diameters upstream and 3-4 pipe diameters downstream should be provided where flow is connected to the meter out of plane with the sensor meter tubes. This is required to avoid different flow velocities being established within the two measuring tubes.

No valves or reducers should be installed between the pipe mounting supports and the sensor.

### 3.6 Accessibility

For accessibility during mounting and maintenance, clearance of at least 10 cm (4”) from the RHM sensor is recommended in every direction.

### 3.7 Vibration

Vibrations can impair the functionality and measurement accuracy of the RHM sensor. Please take into account following:

- The pipe system must be as free as possible from all vibrations. In principle, standard building or system vibrations have no significant impact on the accuracy of the measurement. Nevertheless, heavy vibrations should be avoided at all costs.
- It is recommended that you install the flow meter at a point that vibrates as little as possible. Use solid pipe clamps onto a rigid, non-vibrating surface to decouple the meter from pipe and other vibrations.
- Isolation from mechanical vibrations can also be achieved by using flexible tubes between the sensor and the fixed piping system. Other methods, such as installing the sensor after a bend can also be employed to minimize vibration issues.

- 
- Any unsecured pipe sections situated near the flow meter that might have a tendency to vibrate should definitely be avoided.
  - Both the mechanical design of the flow meter and the implementation of digital filtering in the transmitter signal processing electronics will minimize the effects of vibration on the measurement. However, please note that excessive external vibration can impact measurement performance and, under certain circumstances, cause damage to the flow meter.

### **3.8 Cross Talk**

If two or more RHM mass flow sensors are located close to each other, cross talk may occur between them and measurement precision may be degraded, particularly at low mass flow rates. Sensors should be installed with sufficient spacing to prevent cross talk between them.

### **3.9 Magnetic Interference**

RHM flow sensors must not be installed in environments with strong magnetic fields as these can severely disturb the measurement. Ensure that sensors are installed a sufficient distance from motors, turbo machines, large transformers, electrically operated valves, power contractors etc. to prevent any impact on measurement performance.

### **3.10 Pipe Alignment**

Process connections must meet the sensor face to face length and should be properly aligned. Misaligned pipe connections may exert abnormal forces onto the flow sensor, potentially impacting measurement performance and possibly damage.

### **3.11 Flow Direction**

RHM flow sensors are bi-directional.

If, once the flow meter has been mounted, the flow reading is opposite or negative to the flow reading expected, the flow sense can be corrected by parameter adjustment in the transmitter. Please refer to the RHE transmitter manual for instructions.

### **3.12 Horizontal Pipe Mounting**

The location and orientation of a sensor in line is application dependent although whenever possible, installation of an RHM sensor is preferred in a horizontal pipeline.

- *Liquid applications:* For liquid measurements, the RHM sensor should be installed at a low point in the pipe system with its measurement tubes pointing downwards as this will prevent gas bubbles collecting in the sensor. The presence of gas bubbles can reduce the performance of the sensor for both mass flow and density. See the recommended orientation in Figure 3 (A).
- *Liquid applications with solid particles in the fluid:* If there is a risk that the liquid contains (heavy) solid particles, the RHM sensor should be installed at a high point in the pipe system with its measuring loops pointing upwards to avoid the collection of the particles in the sensor. See the recommended orientation in Figure 3 (B).

*Gas applications:* For gas measurements, the RHM sensor should be installed at a high point in the pipe system with its measuring loops pointing upwards to avoid condensation or other liquids collecting in the sensor. See the recommended orientation in Figure 3 (B).

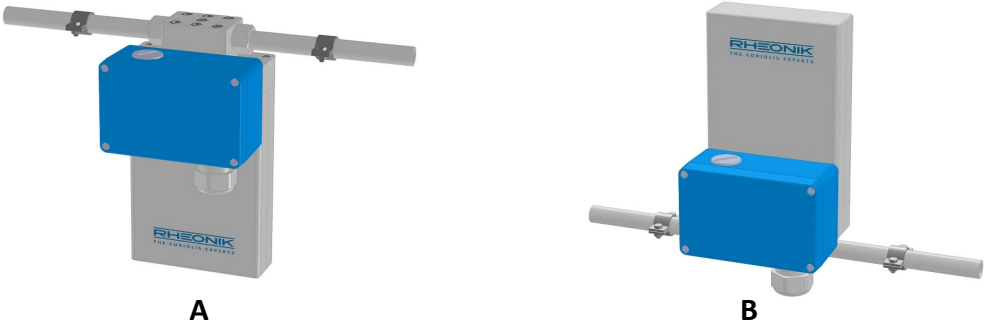

Figure 3: Installation positions for liquid (A) and liquid applications with solid particles/gas applications (B)

It is recommended to install RHM flow sensors with rigid supports at both the inlet and outlet. The supports should be placed apart at a distance of no more than three times the width of the sensor housing.

A range of mounting brackets are available for smaller meters and are highly recommended.

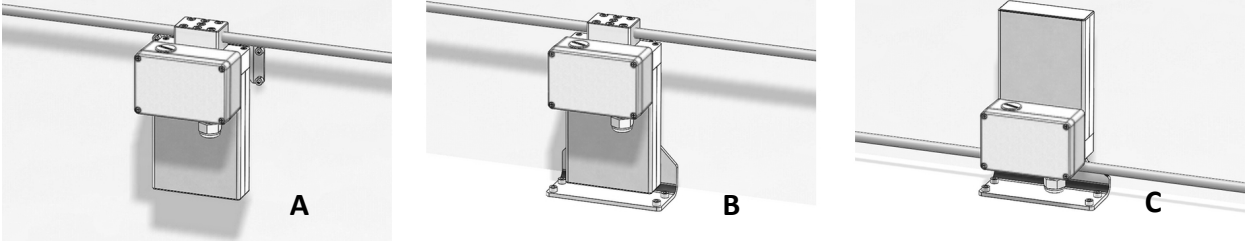

Figure 4: Wall mount bracket (A), floor mount bracket for liquids (B) and floor mount bracket for gas application (C)

Robust supports are needed for large, heavy sensors in order to protect the mechanical integrity of the pipe.

Avoid heavy shocks to the RHM flow meter at any time.

---

### 3.13 Vertical Pipe Installation

Installation of an RHM sensor in a vertical pipe (“flag” installation) is only recommended for pure liquids without gas and solid particles and for dry, non-condensing gases. Due to the internal arrangement of the tubes within the meter, there is the possibility that for low flow liquid installations, gas bubbles and/or solids may accumulate in the meter. For low flow gas installations there is a possibility that some liquids may accumulate in the meter.

For liquid applications with possible gas content, flow should be upwards through the meter to assist in purging and removing accumulated gas from the meter.

Liquid applications with possible content of solid particles should be avoided.

For gas installations the flow should always be downwards through the meter.

When putting the meter into service, it is important to ensure that it is completely filled. To achieve this, a relatively high flow should be introduced to the meter to purge unwanted liquid or gas.

Figure 5 shows the recommended orientation for the flag installation. Notice the two firm supports either side of the meter on the inlet and outlet piping.



*Figure 5: Flag installation*

---

### 3.14 Critical Installations

Figure 6 shows three critical installations.

For an RHM sensor in a liquid application installed in flag position at (A), the pipe should not be open ended below to avoid the RHM sensor running dry.

If solids are expected in a liquid application, or wet gas is being measured, installation at the deepest point of the pipework (B) should be avoided.

If gas bubbles are expected in a liquid application, installation at the highest point of the pipework (C) should be avoided.

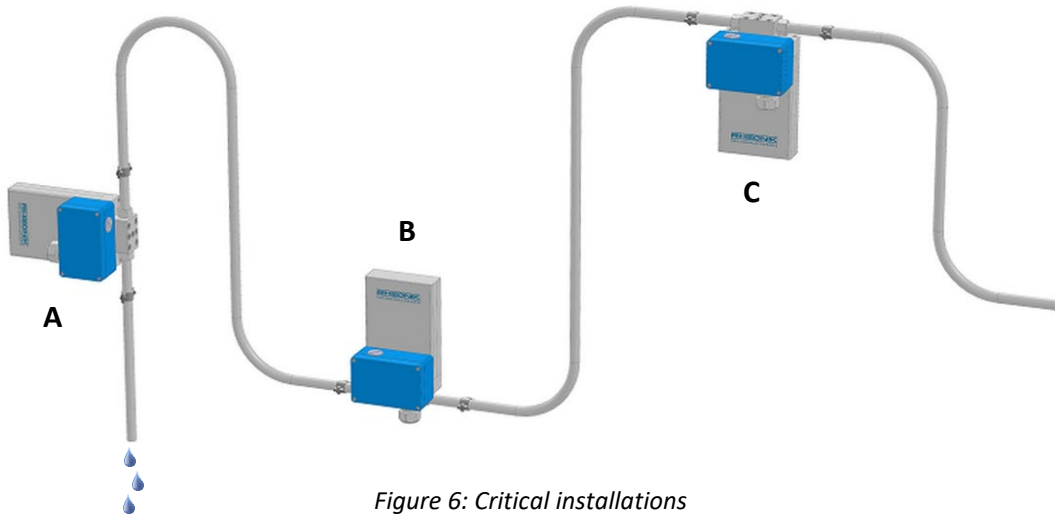

Figure 6: Critical installations

### 3.1 Liquids with low Vapor Pressure

Where a liquid with low vapor pressure is being measured, the system pressure throughout the flow meter must be maintained above the vapor pressure, otherwise cavitation or flashing may occur. Flashing/cavitation can severely impair the performance of the meter. Attention should be paid to other pipeline components (such as valves etc.) upstream of the meter that can also cause cavitation/flashing and affect meter performance. If necessary, a pressure regulator should be installed downstream from the sensor to ensure pressure in the line is maintained above the fluid vapor pressure and therefore, prevent cavitation from occurring. Generally, it is recommended to have backpressure downstream of the flow sensor.

## 4 Electrical Connection to RHE

The RHM sensors are designed for simplest connection to and best operation with all RHE transmitters.

The electrical connection type of the RHM sensor is included in the RHM product and ordering code, please see section 6 for further information.

For the electrical connection to the RHE transmitter please refer to the respective RHE Installation & Startup Guide.



Caution, the surface of the connection box may be hot if a hot fluid is running through the RHM sensor.

---

## 5 Service and Maintenance

### 5.1 Maintenance and Calibration

RHM flow sensors and their associated RHE transmitter do not require any regular maintenance. Under normal circumstances, RHM flow sensors and their associated RHE transmitter should not require flow calibration. If flow calibration is required, either as a one off check or at prescribed intervals to meet statutory or operational requirements, it can be carried out in one of two ways:

- 1) In the field against a certified reference meter or prover
- 2) At a calibration laboratory

Local regulations or contractual/operational requirements will determine the method and interval of such calibrations. Refer to the RHE transmitter manual for full details on calibrating flow meters.

Regular checks of the zero-point calibration are recommended to ensure consistent measurement accuracy and performance.

Density measurement can be calibrated in the field. Please refer to the RHE transmitter manual for instructions.

### 5.2 Troubleshooting

If an RHE transmitter, correctly connected to an RHM flow sensor, displays an error message related to the sensor, the sensor can be checked as follows:

1. With the sensor connected to the RHE flow transmitter, check voltages at the RHM flow sensor terminals using a good quality voltmeter/multimeter. Voltages should be within the ranges given in Table 1 **Fehler! Verweisquelle konnte nicht gefunden werden.Fehler! Verweisquelle konnte nicht gefunden werden..** The difference in the measured voltage between sensor terminals 6-7 and 8-9 should not exceed  $\pm 20\%$ .

Table 1: Sensor voltages

Sensor Terminals	Voltage
1 – 2	0.25 – 5 VAC
6 – 7	10 – 150 mVAC
8 – 9	10 – 150 mVAC

2. With the sensor **disconnected** from the RHE flow transmitter, check internal sensor resistances at the RHM flow sensor terminals using a good quality ohmmeter/multimeter. Resistances should be within the ranges given in Table 2. The difference in the measured resistances between sensor terminals 6-7 and 8-9 should not exceed  $\pm 20\%$ .

Table 2: Sensor resistances

Sensor Terminals	Resistance
1 – 2	5 – 70 $\Omega$
3 – 4	approx. 108 $\Omega^1$ / 1078 $\Omega^2$
4 – 5	approx. 108 $\Omega^1$ / 1078 $\Omega^2$
6 – 7	10 – 160 $\Omega$
8 – 9	10 – 160 $\Omega$
1...9 – Housing	> 10 M $\Omega$ – $\infty$

<sup>1</sup> valid for Pt100 temperature sensor at about 20°C

<sup>2</sup> valid for Pt1000 temperature sensor at about 20°C

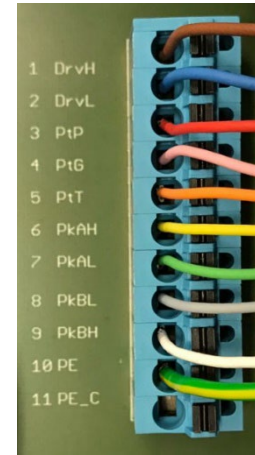

Figure 7: Sensor terminals

If both measured voltage and resistance values do not fall within stated ranges, the RHM flow sensor is defective. If a voltage value only is out of range, the fault may be in the RHE transmitter. In either event, please contact your local sales/support agent or Rheonik Support for assistance.

### 5.3 Service

RHM flow sensors do not contain any user serviceable parts. Please contact your local sales/support agent or Rheonik Support for assistance.

### 5.4 WEEE and RoHS

RHM flow sensors are not subject to the WEEE directive.

RHM flow sensors are fully compliant to the RoHS directive.



---

## Appendix A Ex-Safety Instructions

### A.1 Safety instructions for the installation in a hazardous area:

- The measurement system shall be installed & maintained according to the applicable standards regarding electrical installations in a hazardous areas.
- Before installation, read carefully the operating manual of the RHEONIK Coriolis Flowmeter.
- The mounting, electrical installation, commissioning and maintenance are to be carried out by qualified personal only who are trained in explosion protection.
- All national regulations concerning the installation, maintenance and repair of instruments in explosion hazardous areas must be observed.
- The required temperature class, based on the ambient temperature and the fluid temperature must correspond to the values indicated on the meter type label.
- For the maximum allowed fluid temperatures refer to chapter "A.4 Thermal Safety Limits" in this safety instruction manual.
- For the connection between RHM and RHE only the cable delivered by Rheonik may be used. The use of any other cable shall be clarified with Rheonik beforehand. For intrinsically safe RHM the cable between RHM and RHE (or barrier EZB) is intrinsically safe.
- For safety reasons the total cable length between a RHM sensor and transmitter RHE or a barrier EZB must not exceed 100 meters.
- The connection cables ARHE-C4 and ARHE-C6 are specified for -50°C to +105°C. Temperatures above must be avoided. Temporary temperatures below -50°C are allowed, if the cable is fed in a protecting tube.
- The cable must be fixed close to the RHM in that way that no mechanical stress is applied to the cable gland of the RHM.
- Always close unused cable glands and openings with dummy plugs.
- All cable glands and dummy plugs not provided by Rheonik must comply with all national requirements.
- In accordance with details indicated on the type label, the equipment may be used under conditions where ignitable atmospheres composed of a mixture of air and other gases, steam or dust are present. The equipment is not suitable for mines.
- The sensors RHM are available for zone 0 and 1 (Ex ia or Ex ib) and for zone 2 (Ex ec) as well as for div 1 and 2. Refer to the type label of the RHM for the individual classification.
- Regarding the installation of the transmitter RHE or the barrier EZB refer to the corresponding manual.
- Field wiring of different intrinsically safe circuits shall be separated from each other by at least 0.25 mm thick insulation used on each conductor.
- RHM with hazardous area approvals "C0", "CB", "C2" or "CN" must be grounded. Units with connection type "S\*" provide a grounding terminal on the stainless steel connection box, all other provide an M6 screw with lock washer on the RHM.

---

## A.2 System Description:

### Intrinsically safe RHM:

The system consists of an intrinsically safe mass flow sensor RHM and a certified transmitter RHE (or equivalent) with built in or external barrier.

The intrinsically safe mass flow sensor RHM can – depending on the individual certification – be mounted in zone 0, zone 1 or zone 2. For the American market versions for div 1 and for div 2 are available.

Transmitters RHE with barrier as well as dedicated barriers EZB are available for mounting in zone 1 and zone 2 as well as in div 1 and div 2.

### RHM with protection type ec or nA:

The system consists of a flow sensor RHM and any transmitter RHE by Rheonik.

The mass flow sensor “Ex ec” or “Ex nA” can be mounted in zone 2.

## A.3 Electrical Safety Limits

### Intrinsically safe RHM:

Circuit name	Terminals	Ui [V]	Ii [mA]	Pi [mW]	Li [mH]	Ci [nF]
Drive circuit	1 - 2	9.3	144	335	1.5 *)	<10
Temp. sense	3-4, 5-4	7,4	58	107	<0.1	<10
Pickup circuit	6-7, 9-8	7,4	29	54	4.5	<10

\*) With hazardous areas approval code “AA”, “AB”, “CA” or “CB”: Li = 6.5mH

### Notes:

If the type label of the RHM specify different values, the values on the type label are to be observed!

The values for Li and Ci include the influence of the cable for connection types “T\*” (fixed cable).

Only transmitters with linear barriers with negligible Li and Ci values may be used. All approved Rheonik transmitters RHE\*\* comply with this requirement.

The terminal numbers are the numbers in the connection boxes (connection type J\*, S\*).

For the cable colors for connection type “T\*” (fixed cable) refer to the drawings in chapter A.6.

RHM with temperature ranges above 210°C (temperature code H\*) and below -50°C (e.g. temperature code E3) must only be operated with certified transmitters by Rheonik with grounded circuits.

Between RHM and transmitter potential equalization must exist.

### RHM with protection type ec or nA:

The RHM must only be connected to any transmitter RHE by Rheonik.

RHM with connection type “J9” or “S9” are connected to a RHE49 ex work. The interconnection points are not accessible from outside.

#### A.4 Thermal Safety Limits

**Note:**

Some temperature ranges specify narrower temperature ranges than the maximum ranges indicated below. The range E3 for example is specified for -196°C to +50°C. In that case the limits on the type label must be observed.

For all temperature ranges the body of the RHM may be completely isolated for reducing the heat transfer between ambient and fluid, as long as the connection box remains outside the insulation.

The temperature of the connection box must not be less than -50°C or more than +105°C.

The connection cables ARHE-C4 and ARHE-C6 are specified for -50°C to +105°C. They can be used at temperatures below -50°C, if they are fed in a rigid tube.

With RHM\*\*\* type TM (fixed Teflon cable) the cable withstands -196°C to +205°C.

**Warning:**

Compact versions with RHE42 or RHE49 have limited temperature ranges. Refer to the individual description below.

**Temperature Ranges N\***

The mass flow sensors with temperature ranges N\* cover different temperature ranges in the total range from -50°C to +120°C.

Temperature class	T6	T5	T4	T3	T2	T1
Min. temperature	-50°C	-50°C	-50°C	-50°C	-50°C	-50°C
Max. ambient temperature	65°C	80°C	80°C	80°C	80°C	80°C
Max. fluid/gas temperature	65°C	80°C	115°C	120°C	120°C	120°C

**Temperature Ranges N1, NA with RHE42**

Ordering code: MaaN\*PPCCMMFFC2

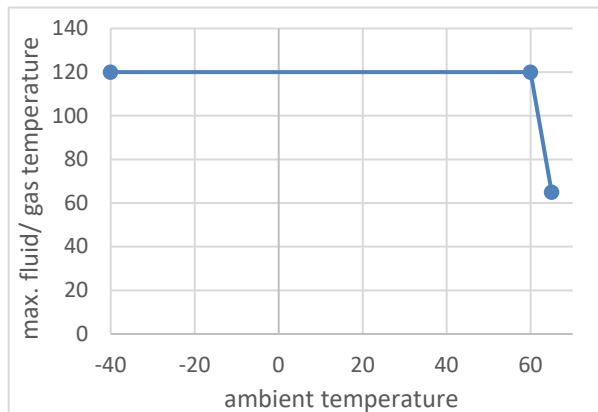

Minimum fluid and ambient temperature: -20°C (N1) or -40°C (NA)

### Temperature Ranges N1, NA with RHE49, front mount

Ordering code: MaaN\*PPCCMMFFJ9 or MaaN\*PPCCMMFFS9

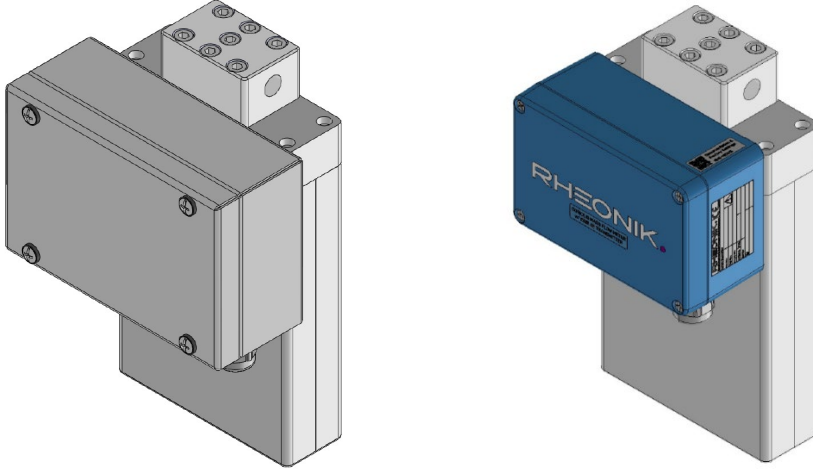

Front mount with stainless-steel housing (left) or aluminum housing (right)

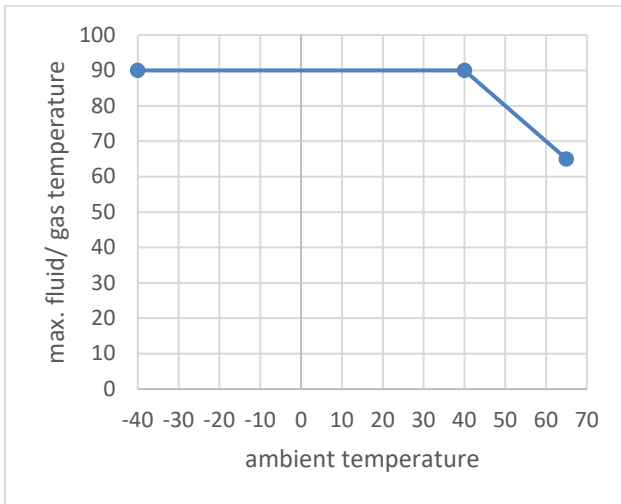

Minimum fluid and ambient temperature: -20°C (N1) or -40°C (NA)

### Temperature Ranges E\*

The mass flow sensors with temperature ranges E\* cover different temperature ranges in the total range from -196°C to +210°C.

Temperature class	T6	T5	T4	T3	T2	T1
Min. ambient temperature	-50°C*	-50°C*	-50°C*	-50°C*	-50°C*	-50°C*
Min. flow temperature	-196°C*	-196°C*	-196°C*	-196°C*	-196°C*	-196°C*
Max. ambient temperature	65°C	80°C	80°C	80°C	80°C	80°C
Max. fluid/gas temperature	65°C	80°C	115°C	180°C	210°C	210°C

\*) At ambient temperature below -40°C the minimum flow temperature rises linearly from -196°C at -40°C ambient temperature to -50°C at -50°C ambient temperature, see graph below.

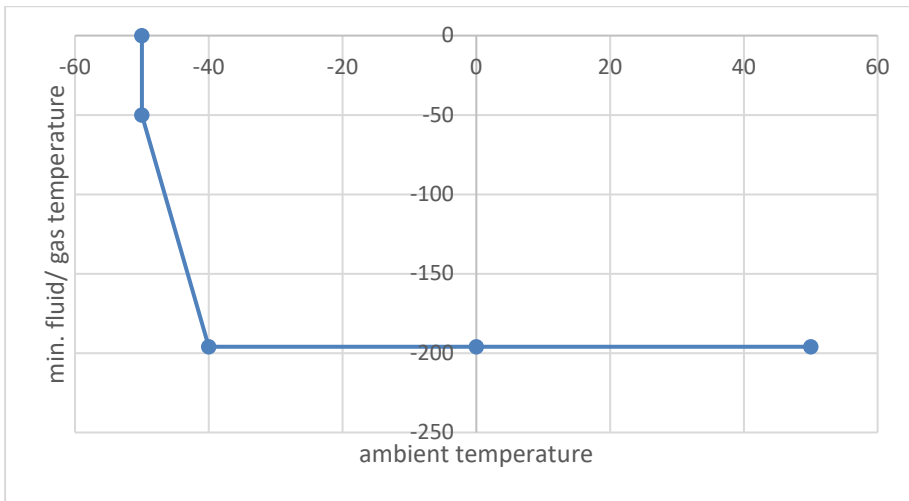

Derating of minimum fluid/gas temperature for low ambient temperatures.

### Temperature Range E2 with RHE42

Ordering code: MaaaE2PPCCMMFFC2

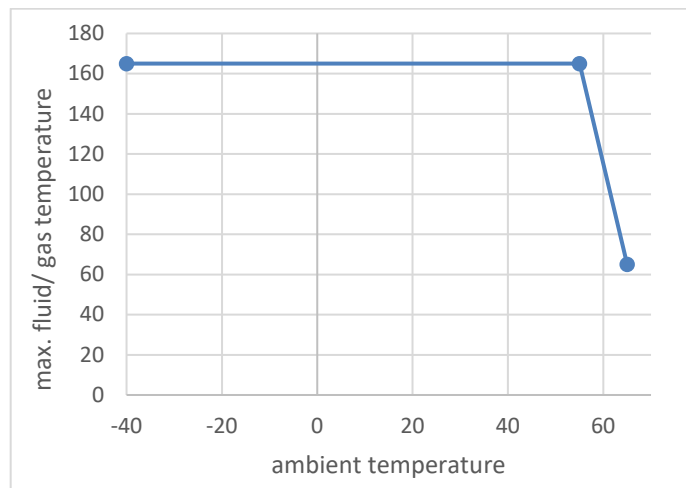

Minimum fluid and ambient temperature: -40°C

### Temperature Range E2 with RHE49, distance mount

Ordering code: MaaaE2PPCCMMFFJ9 or MaaaE2PPCCMMFFS9

Note: The picture just shows the aluminum housing (J9) but the curve is valid for the stainless steel housing (S9) as well.

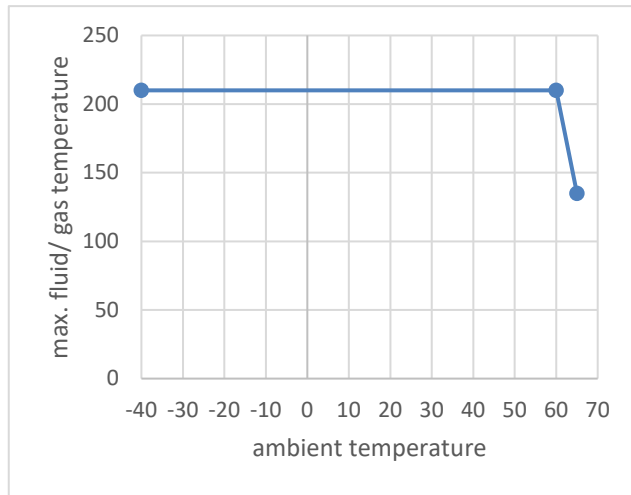
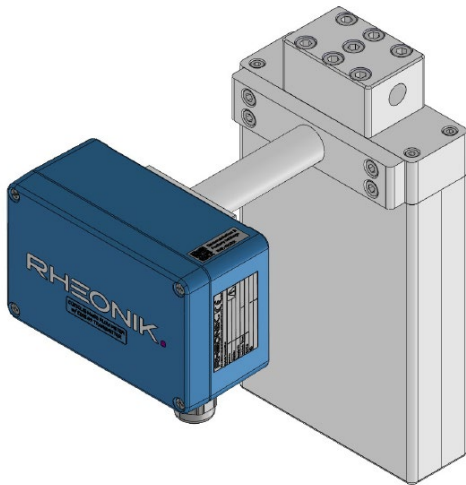

Minimum fluid and ambient temperature: -40°C

### Temperature Range N1, NA and E2 with RHE49, Top mount

Ordering code: MaaaE2(N1, NA)PPCCMMFFJ9 or MaaaE2(N1, NA)PPCCMMFFS9

Note: The picture just shows the aluminum housing (J9) but the curve is valid for the stainless steel housing (S9) as well.

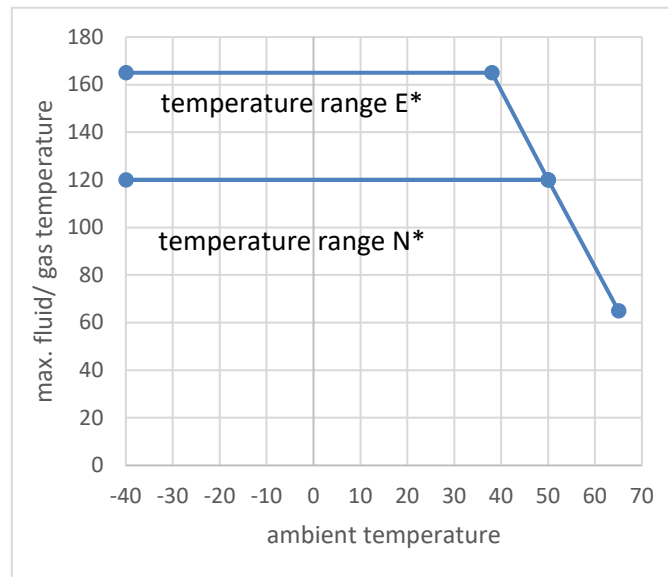
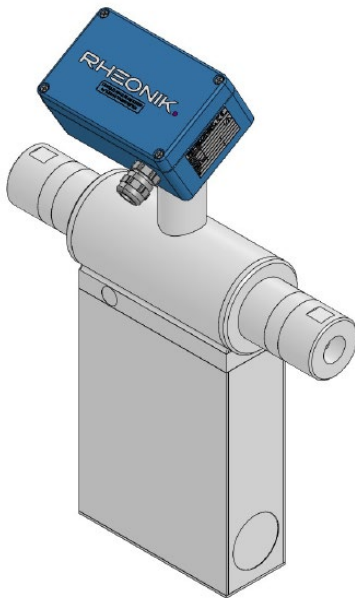

Minimum fluid and ambient temperature: -20°C (N1) or -40°C (NA, E2)

### Temperature Ranges H\*

The mass flow sensors with temperature ranges H\* cover different temperature ranges in the total range from -20°C to +400°C.

The optimum operation temperature is 100°C to 400°C. For permanent operation temperatures below 100°C we recommend the use of sensors with a temperature range N\* or E\*.

Temperature class	T6	T5	T4	T3	T2	T1
Min. temperature	-	-	-20°C	-20°C	-20°C	-20°C
Max. ambient temperature	-	-	80°C	80°C	80°C	80°C
Max. fluid/gas temperature	-	-	105°C	170°C	270°C	400°C

## A.5 Grounding

IEC60079-0 recommends to ground shielded cables just on one end, normally outside the hazardous area. On the other side the shield may be grounded via a 1nF capacitor.

In small installations (cable length typically less than 10m) the shield can be grounded on both sides, provided that there is no potential difference between PE at the RHM and PE at the RHE. This can be assumed if there is a good metallic contact or if a dedicated PE cable of at least 4mm<sup>2</sup> connects the two grounding points.

With the connection versions J\* and S\* terminal 10 (PE) is connected directly to case and terminal 11 (PE\_C) is connected to the case via a 1nF / 1000V capacitor. The shield can and should be connected directly to one of these terminals, depending on the guidelines mentioned above.

With the connection versions T\* the shield is connected to the housing of the RHM. As the standard cable length is 2m, the shield normally can be connected to the PE terminal of the RHE. If this is not allowed due to local restrictions, use a 1nF /1000V in series.

Units with connection type "S\*" provide a grounding terminal on the stainless steel connection box, all other provide an M6 screw with lock washer on the RHM ground plane.

## A.6 Electrical connection to RHE

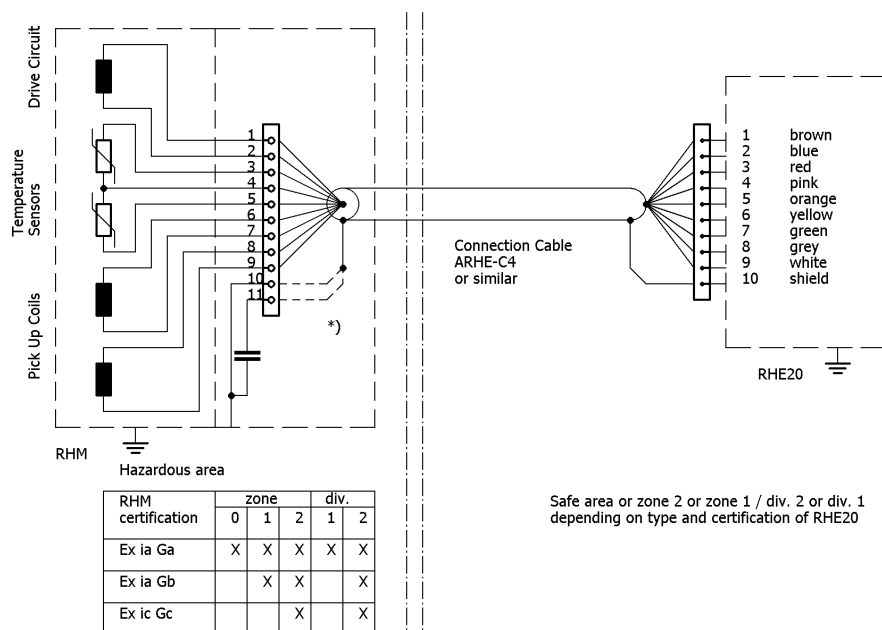

Electrical connections between RHM\*\*\* connection type S\*, J\* (connection box) and a RHE20.

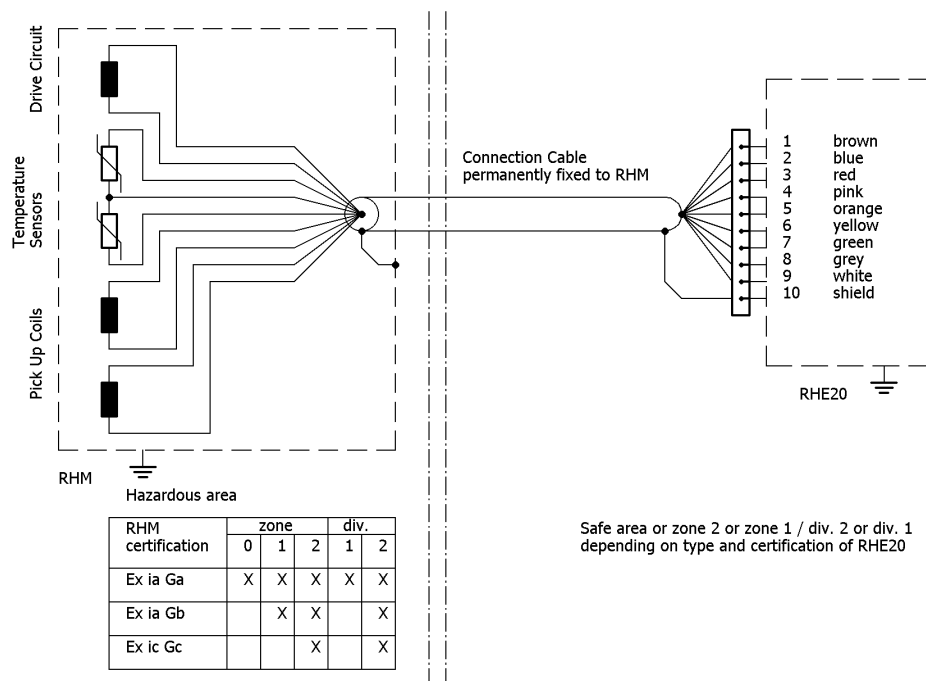

Safe area or zone 2 or zone 1 / div. 2 or div. 1 depending on type and certification of RHE20

Electrical connections between RHM\*\*\* connection type T\* (fixed cable) and a RHE20.

**RHM with RHE42 (connection type C2)**

With connection type C2 the electronics RHE42 is mounted on top of the RHM and the interconnection between RHM and RHE is not accessible from outside.

RHM and RHE must not be separated.

**RHM with RHE49 (connection type J9 and S9)**

With connection type J9 and S9 the electronics RHE49 is included into the connection box and the interconnection between RHM and RHE is not accessible from outside.

RHM and RHE must not be separated.

---

## A.7 Ordering Code

The following extract of the ordering code shows the information relevant for hazardous areas.

MaaaTTPPCCMMFFCC-OO-EE (may be followed by codes for additional options)

Maaa	Meter size, see complete order code in the main manual
TT	Fluid Temperature range N1 = -20°C to +120°C NA = -50°C to +120°C N* = special temperature ranges between -50°C and +120°C E2 = -50°C to +210°C E3 = -196°C to +50°C E* = special temperature ranges between -196°C and +210°C H4 = -20°C to +350°C H5 = -20°C to +400°C H* = special temperature ranges between -20°C and +400°C
PPCCMMFF	Pressure range, Construction type, Material, Process connection
CC	Connection type and electrical properties C2 = top flange for mounting RHE42 (compact version) JC = aluminum connection box, Pt100 J9 = aluminum housing for RHE49 JM = aluminum connection box, 2 Pt1000 PM = small aluminum connection box, 2 Pt1000 SC = stainless steel connection box, Pt100 SM = stainless steel connection box, 2 Pt1000 S9 = stainless steel housing for RHE49 TM = fixed cable, 2 Pt1000 (temperature N* and E*)
OO	Special options
EE	Hazardous areas approvals A0 = ATEX / IECEx zone 0    II 1G Ex ia IIC T* Ga A1 = ATEX / IECEx zone 1    II 2G Ex ib IIC T* Gb AA, AB = ATEX / IECEx zone 0 II 1G Ex ia IIB T* Ga (only connection type S*) = ATEX / IECEx zone 1    II 2G Ex ib IIB T* Gb (not connection type S*) A2 = ATEX / IECEx zone 2    II 3G Ex ec IIC T* Gc AN = ATEX / IECEx zone 2    II 3G Ex ec IIB T* Gc C0 = CSA zone 0 / div. 1    group IIC / A, B, C, D T* CA, CB = CSA zone 0 / div. 1 group IIB / C, D T* C2 = CSA zone 2 / div 2    group IIC / A, B, C, D T* CN = CSA zone 2 / div. 2    group IIB / C, D T* U0 = A0 plus C0 U1 = A1 plus C0 UA = AA or AB plus CA or CB U2 = A2 plus C2 UB = AN plus CN

Not all combinations are possible. For available combinations see instructions.

The temperature class T\* depends on the meter type and the specified fluid temperature range "TT", refer to the label on the meter.

---

Where no versions for the place holders are specified, these parameters are not relevant for the Ex certification. Where versions are specified (e. g. for “cc connection type”: SM, TM etc.), versions not listed here are not available with Ex certification.

The asterisk \* is a placeholder for special custom specific versions within the specified range. Regarding the electrical and thermal limits of special versions refer to the type label of the unit.

## **A.8 Technical Data**

The following limits are valid for safe operation in hazardous areas:

Electrical data:	Refer to chapter A.3 and to the information on the type label
Operating temperatures:	Refer to chapter A.4 and to the information on the type label
Fluid / gas pressure:	Refer to the type label
Pollution degree:	3
Installation category:	I
Humidity:	0 to 100% relative humidity
Altitude:	up to 3000m, higher maximum altitude upon request
IP rating:	See type label. IP*8 is specified as 1 hour at 2 m water depth.

Connection cable ARHE-C4 and ARHE-C6:

Operating Temperatures:	-50°C to +105°C
Resistance:	39 Ω/km (blue, brown), 56 Ω/km (all other wires)
Inductance:	< 0.7μH/m
Capacitance wire-wire:	< 90 pF/m
Capacitance wire-shield:	< 175 pF/m

## **A.9 Service and repair**

The unit does not contain any user serviceable parts and must not be opened by the user.

If the unit gets opened, the Ex-certification gets void.

In case of malfunction connect your dealer or directly Rheonik Messtechnik GmbH

## **A.10 Contact address**

Rheonik Messtechnik GmbH

Rudolf-Diesel-Str. 5

85235 Odelzhausen

Germany

[www.rheonik.com](http://www.rheonik.com)

[info@rheonik.com](mailto:info@rheonik.com)





## About Rheonik

Rheonik has but one single purpose: to design and manufacture the very best Coriolis meters available.

Our research and engineering resources are dedicated to finding new and better ways to provide cost effective accurate mass flow solutions that provide value to our customers. Our manufacturing group care for each and every meter we produce from raw materials all the way to shipping, and our service and support group are available to help you specify, integrate, start-up and maintain every Rheonik meter you have in service. Whether you own just one meter or have hundreds, you will never be just another customer to us. You are our valued business partner.

Need a specific configuration for your plant? Don't compromise with a "standard" product from elsewhere that will add extra cost to your installation. If we can't configure it from our extensive and versatile product range, our exclusive **AnyPipeFit Commitment** can have your flow sensor customized with any size/type of process connection and face to face dimension you need.

No matter what control system you use as the backbone in your enterprise, with our **AnyInterface Commitment**, you can be sure that connection and communication will not be a problem. Alongside a wide variety of discrete analog and digital signal connections, we can also provide just about any network/bus interface available (for example: HART, ProfibusDP, ProfiNet, EtherCAT, PowerLink, EtherNet/IP, CAN, ....) with our RHE 40 Series family of transmitters. Rheonik RHE 40 Series transmitters can connect to your system – no headache and no conversion needed.

Rheonik Messtechnik GmbH  
Rudolf-Diesel-Straße 5  
D-85235 Odelzhausen  
Germany

Tel + 49 (0)8134 9341-0  
info@rheonik.com



## Addendum to:

RHM Coriolis Sensor User Manual, RHM015 - RHM20 - Doc. No. 8.2.1.10 Version 1.37

RHM Coriolis Sensor User Manual, RHM30 – RHM160 - Doc. No. 8.2.1.13 Version 1.36

## Additional information to chapter 2:

### 2.4.1 Type Label Update

As part of a required update for PED-certified RHM's, the type label may differ from the one shown in chapter 2.4.





 Rheonik Messtechnik GmbH Germany, 85235 Odelzhausen, Rudolf-Diesel-Straße 5				Class I, Zone 0, AEx ia IIC T6...T1 Ga			Ex ia IIC T6...T1 Ga			 C US 220495				
				Class I, Div. 1, Groups A, B, C and D T6...T1			CSA 18CA70138578							
Coriolis Flow Sensor RHM 100 FNT (p) - 8" CL 150														
Order Code: M101N1P0PF0M1A1JM-NN-U1							T6	T5	T4	T3	T2	T1		
Ser. No.: RHM-123456				Min Ambient Temp.			-20°C	-20°C	-20°C	-20°C	-20°C	-20°C		
TAG No.: TAG Number				Min Process Temp.			-20°C	-20°C	-20°C	-20°C	-20°C	-20°C		
Product Group PRESSURE ACCESSORIES				Max Ambient Temp.			65°C	80°C	80°C	80°C	80°C	80°C		
Nom. Flow [kg/min]:		10000		F1		Max Process Temp.			65°C	80°C	115°C	120°C	120°C	120°C
Nom. Diam. [DN]:		100 / 200		(Tube / Connection)										
PS [barg]:		20	19,5	16,5	PT [barg]:		28,5	Intrinsically Safe Circuits Pins    Ui (V)    Ii (mA)    Pi (mW)    Ci (nF)    Li (mH)						
TS [°C]:		-20	50	120	TT [°C]:		20						L	
Prot. Rating:		GH		IP66 / Type 4X			Drive Circuits		1-2	9.3	144	335	10	1.5
Connection:		8" ANSI CL 150 RF SF			Pickup Circuits		6-7 9-8	7.4	29	54	10	4.5		
Wetted Parts:		M		1.4571 / SS 316Ti, 1.4571 / SS 316Ti, no seals / welded			Temperature Sensor		3-4 5-4	7.4	58	107	10	0.1
Test Date / MFG Date:		15.07.2025 / 2025		Made in Germany										
 0036 0044		Flashing Liquids not allowed Fluid group 1 EN 13480 Category II N				 II 2G Ex ib IIC T6...T1 Gb			BVS 17 ATEX E 074 X					
						Ex ib IIC T6...T1 Gb			IECEx BVS 17.0063X					

Figure 1: New type label design with further information.

- F1 Additional information on the nominal diameter of the tube and connection
- GH Maximum operating pressure depending on temperature in table form
- L Test pressure and test temperature used
- M Internal test date / Manufacturing date
- N Additional information for the PED-Certification (if applicable)

## Additional Information to Chapter 4:

### 4.1 Cable glands

#### Note for devices in hazardous areas:

The pressure screw must be tightened so that the sealing insert is flush with its upper edge.

Do not exceed the maximum tightening torques (see Table 1).

Lower torques are possible, however.

**CAUTION:** It is essential to avoid excessive swelling of the sealing insert!

Cable gland (Size)	Maximum tightening torques pressure
Pflitsch bg220**HTex (M20)	10 Nm

Table 1: Maximum tightening torques for the cable glands used by Rheonik. \*\* is used as a placeholder for the material.

## Additional Information to Appendix A:

### A.11 Additional technical data for devices with CSA certification

The following limits are valid for safe operation in hazardous areas:

Electrical data:	Refer to chapter A3 and to the information on the letter plate
Operating temperatures:	Refer to chapter A4 and to the information on the letter plate
Fluid / gas pressure:	Refer to the letter plate
Pollution degree:	3
Installation category:	I
Humidity:	0 to 100% relative humidity
Altitude:	up to 3000m, higher maximum altitude upon request
Electrical connection:	to Class 2 circuit
IP rating:	See letter plate. IP*8 is specified as 1 hour at 2 m water depth.
Outdoor use	