

RHEONIK.



RHE 21 User Manual



Rheonik Messtechnik GmbH
Rudolf-Diesel-Straße 5
D-85235 Odelzhausen
Germany

Tel + 49 (0)8134 9341-0
info@rheonik.com

LEARN
MORE



Document No.: 8.2.1.04
Version 1.35
February 2024

RHE 21

Transmitter

User Manual

RHEONIK.

Table of Content

1	General Information	7
1.1	Intended Use	7
1.2	Intended Use RHE21	7
1.3	Impermissible use	7
1.4	Important Safety Instructions for operating Coriolis Flowmeters	8
1.5	Manufacturer's Liability	8
1.6	Additional Resources	8
2	Quick Start	8
3	Installation	9
3.1	Mechanical Installation	9
3.2	Electrical Installation	9
3.2.1	Interconnecting RHE/RHM	10
3.2.1.1	RHM Electrical Connection Type JM & SM (11 Terminals)	10
3.2.1.2	RHM Electrical Connection Type TM (PTFE Cable)	11
3.2.1.3	RHM Electrical Connection Type JO (12 Terminals)	12
3.2.1.4	Legacy RHM Sensors (9 Terminals)	13
3.2.2	Power Supply, Grounding and I/O Connections Overview	14
3.2.2.1	Grounding	16
3.2.2.2	12V to 24V DC Power Supply	16
3.2.2.3	100V to 240V AC Power Supply	16
3.2.2.4	AC and DC Supply	17
3.2.3	Control Inputs and Outputs	17
3.2.3.1	Digital Outputs	17
3.2.3.2	Analog Outputs	19
3.2.3.3	Digital Inputs	21
3.2.3.4	Analog Input	22
4	Operation and Configuration	23
4.1	Function of the Pushbuttons	23
4.2	Passcodes and Menu Selection	24
4.3	Zero Offset Calibration	24
4.4	Change of Positive Flow Direction	25
4.5	Temperature Measurement Configuration	26
4.6	Output Configuration	27
4.6.1	Analog Output Configuration	27

4.6.2	<i>Digital Output Configuration</i>	28
4.6.3	<i>Digital Input Configuration</i>	31
5	<i>Remote Operation</i>	32
5.1	<i>RS485</i>	32
5.2	<i>HART</i>	33
6	<i>Service and Maintenance</i>	34
6.1	<i>Maintenance and Calibration</i>	34
6.2	<i>Troubleshooting</i>	34
6.3	<i>Service</i>	34
6.4	<i>WEEE and RoHS</i>	35
7	<i>Ordering Code</i>	35
Appendix A	<i>Ex-Safety Instructions</i>	36
A.1	<i>Safety instructions for the installation in a hazardous area:</i>	36
A.2	<i>System Description:</i>	37
A.3	<i>Electrical Safety Limits</i>	37
A.4	<i>Thermal Safety Limits</i>	39
A.5	<i>Grounding and Shielding</i>	39
A.6	<i>Installation</i>	39
A.7	<i>Electrical connection of power supply and I/O</i>	41
A.8	<i>Electrical connection to RHM and pressure sensor</i>	41
A.9	<i>Ordering Code</i>	43
A.10	<i>Technical Data</i>	44
A.11	<i>Compliance</i>	44
A.12	<i>Service and repair</i>	45
A.13	<i>Contact address</i>	45
Appendix B	<i>Technical Information</i>	46
B.1	<i>Technical Data</i>	46
B.2	<i>Mechanical Drawings</i>	48
B.3	<i>Mounting Drawing</i>	54

1 General Information

1.1 Intended Use

Rheonik Coriolis mass flow measuring instruments consisting of a sensor (RHM), a transmitter (RHE), and in some cases, an interconnecting cable, are intended for measuring liquids and gases. The operator must ensure that the instrument is only used in a way that complies with limitations and certifications listed on the instrument type plates. These limitations/certifications include, but are not limited to:

- Pressure and temperature ranges
- Approval limits (e.g., explosion protection, pressure equipment directive)
- Suitability of the materials of construction in contact with the process

The instrument must be installed, operated, and maintained in accordance with the manufacturer's instructions and guidelines. The instrument must not be modified or altered in any way that has not been approved by the manufacturer or certification body. Regular inspections and preventive maintenance should be carried out to ensure ongoing safety and performance. Use not in accordance.

1.2 Intended Use RHE21

The RHE21 Coriolis transmitter displays the measured values for RHM Coriolis sensors. It can display the mass flow of liquids and gases as well as the medium density and medium temperature. In addition, the RHE21 Coriolis transmitter is able to calculate variables such as the volume.

Only install and operate the RHE21 Coriolis transmitter in locations with the following ambient conditions:

- Ambient temperature -20 to +60 °C (optionally -40 to +60 °C), see specification on type label
- Altitude of max. 3000 m above sea level
- Relative humidity of 10 to 95% (non-condensing)
- In shade; not exposed to direct sunlight

1.3 Impermissible use

The following are examples of impermissible use of the RHE21 Coriolis transmitter (i.e. use contrary to its intended use):

- Using the RHE21 Coriolis transmitter in locations other than those specified above.
- Using the device in life-support systems in the medical, motor vehicle, aircraft, watercraft, or mining industries.

1.4 Important Safety Instructions for operating Coriolis Flowmeters



For RHE21 units requiring 12 to 24V DC power, the use of a properly grounded (PELV) supply is highly recommended.

The use of shielded cables for all I/O signals is recommended to prevent interference from high level EMI.

Only the specifically designed shielded cable supplied by Rheonik should be used to connect RHE Transmitters to RHM Flow Sensors. Do not use other types of cable.

For safety instructions regarding RHM Coriolis Flow Sensors, please refer to the RHM installation and startup guide manual.

All national regulations and standards regarding electrical installation must be observed!

1.5 Manufacturer's Liability



Rheonik assumes no liability for loss and/or consequential damages stemming from the use of this product utilized in life-preserving systems in the medical, motor vehicle, aircraft, watercraft, or mining industries.

Rheonik accepts no liability for loss or damage resulting from the improper use of any of its products.

Rheonik assumes no liability for the loss of production and/or consequential damage from the use of this product unless such liability has been expressly and contractually agreed.

Rheonik provides a standard one year from shipment warranty on all products for workmanship and materials. Performance of this warranty will be at the Rheonik manufacturing facility.

Rheonik assumes no liability for determining the suitability of its products in any specific application. This is the sole responsibility of the end user.

1.6 Additional Resources

This guide is intended as a quick reference instruction to aid the installation and startup of an RHE21 Coriolis mass flow transmitter with an RHM flow sensor and is a supplement to the documentation found in the RHE2X Desktop Reference. The RHE2X Desktop Reference and further resources are available for download from the Rheonik website:

www.rheonik.com

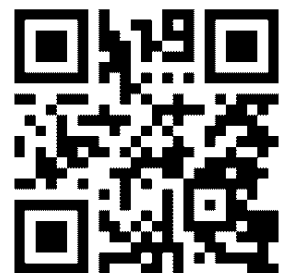

2 Quick Start

A complete flowmeter system typically consists of a:

- RHMxxx Sensor
- RHExx Transmitter
- Interconnection cable

Carry out the following steps to prepare the flow meter for operation:

-
- 1) If not already done, install the RHM sensor in line (refer to the RHM Coriolis Sensor installation and startup guide for additional information on mechanical installation). Connect the interconnecting cable to the RHE using the terminating scheme that matches the RHM electrical connection type (see section 3.2.1 for electrical termination schemes).
 - 2) Connect all signal input, output and communications interface wiring as required (section 3.2.3).
 - 3) Connect power supply (section 3.2.2).

NOTE:

For safety, always connect the protective ground.

For installations in hazardous areas, a protective ground must always be connected.

- 4) Switch on the power supply. The display backlight will light up and after a power up sequence, the display will show the flow measurement screen. In case of an error the backlight will turn red.
- 5) Flush the RHM flow sensor with process fluid and ensure that it is free of air bubbles (in case of a liquid process fluid) or liquid droplets (in case of a gaseous process fluid).
- 6) Wait until the RHM temperature has stabilized and then carry out a zero-point calibration (section 4.3):
 - Ensure a zero-flow condition is present in the flow sensor by closing isolation valves
 - Initiate zeroing of the sensor and wait for the zeroing procedure to complete
 - Open isolation valves to allow flow through the sensor

3 Installation

3.1 Mechanical Installation

The RHE21 transmitter are designed for wall or pipe bracket mounting in harsh environment. The enclosure is rated IP66 / type 4X. The RHE21-EP can also be installed behind a panel.

The RHE21 should be mounted with 4 screws M6 or #12 (e.g. UNC12-24) on a metal mounting plate with minimum thickness of 6mm (1/4").

Note: The screw must enter the nut by at least 4 full turns!

Alternatively, a pipe mounting is possible. A set of 2 pipe brackets is available as accessory.

The mechanical drawings of the different RHE21 as well as the mounting drawing for pipe bracket mounting can be found in appendix B.

3.2 Electrical Installation



Caution, the surface of the connection box may be hot if a hot fluid is running through the RHM sensor.



Unused cable entries at the RHE21 have to be closed by suitable sealing plugs.

Electrical connections to the transmitter are made either with screw terminals or push-in connectors. To connect or disconnect a wire to a push-in connector push down the cable release operator while inserting or drawing out the wire.

3.2.1 Interconnecting RHE/RHM

Except for the RHE21 construction types E5 and H3 all RHE21 are delivered with an integrated cable for connection with an RHM sensor. They can be directly connected to the RHM sensor according to Tables 2 to 5.

The RHE21 construction types E5 and H3 have to be connected to an RHM sensor according to Tables 2 to 5 using the bottom RHE21 terminal box. **Only interconnecting cable (ARHE-Cx cable) supplied by Rheonik should be used to connect an RHE to an RHM.** Cable not supplied by Rheonik may lead to a poor performance of the Coriolis mass flow meter.

Table 1: Overview RHM electrical connection types

RHM electrical connection type	Junction box / terminals	Section
JM, SM	aluminium, stainless steel / 11	3.1.1.1
TM	- / PTFE cable with 9 wires + shield	3.1.1.2
JO	aluminium / 12	3.1.1.3
legacy type	aluminium, stainless steel / 9	3.1.1.4

3.2.1.1 RHM Electrical Connection Type JM & SM (11 Terminals)

Table 2: RHE21 Wiring Plan for RHM Connection Types JM, SM

RHM Terminal		Cable		RHE21 Terminal ¹	
No.	Name	Wire Color	Function	No.	Name
1	DRV H	Brown	Drive Coil high	1	DrvH
2	DRV L	Blue	Drive Coil low	2	DrvL
3	PT P	Red	Temperature Sensor Pipe	3	PtP
4	PT G	Pink	Temperature Sensors GND	4	PtG
5	PT T	Orange	Temperature Sensor Torsion	5	PtT
6	PUA H	Yellow	Pick Up Coil A high	6	PkAH
7	PUA L	Green	Pick Up Coil A low	7	PkAL
8	PUB L	Grey	Pick Up Coil B low	8	PkBL
9	PUB H	White	Pick Up Coil B high	9	PkBH
10 ²	PE	(yel/grn)	Shield	10	PE
11 ²	PE C	(yel/grn)			

¹ Connection only necessary for RHE21 construction types E5 and H3 without integrated sensor cable.

² The RHM has 2 terminals for the connection of the cable shield. One is connected directly to PE, the other via a 1nF capacitor (PE C).

The best protection against RF EMI is achieved if the cable shield is connected at both ends. In installations with a long interconnecting cable between RHE and RHM, significant potential difference between the PE at the RHE and the PE at the RHM may occur. Connecting the shield to PE at both ends might lead to undesirable current flow in the shield. In situations where a high potential difference is present between the RHE and RHM, we recommend grounding via the PE C terminal on the RHM side.

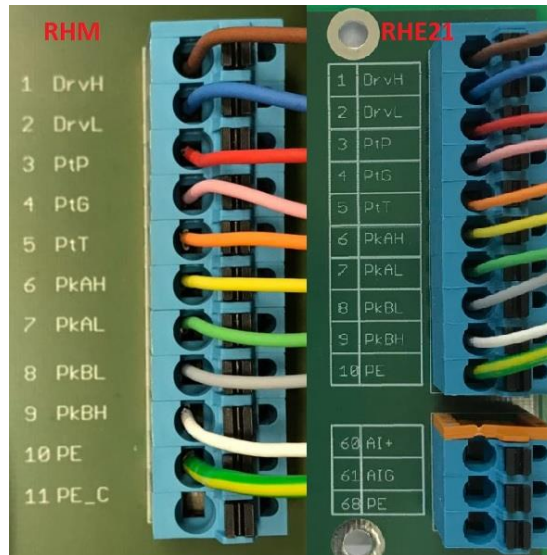

Figure 1: RHE21 Wiring with RHM Connection Types JM, SM

Upon power up, if the RHE indicates an error and the temperature measurement on the bottom right of the display shows “-.-°C/°F” please check the temperature measurement configuration setting in the RHE (section 4.5).

The correct temperature measurement configuration setting for an RHM with connection type JM or SM is “7”.

3.2.1.2 RHM Electrical Connection Type TM (PTFE Cable)

Table 3: RHE21 Wiring Plan for RHM Connection Type TM

Cable			RHE21 Terminal	
No.	Wire Color	Function	No.	Name
1	Brown	Drive Coil high	1	DrvH
2	Blue	Drive Coil low	2	DrvL
3	Red	Temp. Sensor Pipe	3	PtP
4	Pink	Temp. Sensors GND	4	PtG
5	Orange	Temp. Sensor Torsion	5	PtT
6	Yellow	Pick Up Coil A high	6	PkAH
7	Green	Pick Up Coil A low	7	PkAL
8	Grey	Pick Up Coil B low	8	PkBL
9	White	Pick Up Coil B high	9	PkBH
10 ¹	(yel/grn)	Shield	10	PE



Figure 2: RHE21 Wiring with RHM Connection Type TM

¹ The shield of the cable is connected internally to the housing of the RHM. If there is a risk of a significant potential difference between the housing of the RHM and the PE terminal of the RHE, the shield should be connected to the RHE PE connection via a 1nF capacitor. Alternatively, a separate cable can be run for potential equalization between the RHM case and the RHE and the shield left both unconnected and isolated at the RHE or terminated to the PE connection via a 1nF capacitor.

Upon power up, if the RHE indicates an error and the temperature measurement on the bottom right of the display shows “-.-°C/°F” please check the temperature measurement configuration setting in the RHE (section 4.5).

The correct temperature measurement configuration setting for an RHM with connection type TM is “7”.

3.2.1.3 RHM Electrical Connection Type JO (12 Terminals)

Table 4: RHE21 Wiring Plan for RHM Connection Types JO

RHM Terminal		Cable		RHE21 Terminal ¹	
No.	Name	Wire Color	Function	No.	Name
1	DRIVE +	Brown	Drive Coil high	1	DrvH
2	DRIVE -	Blue	Drive Coil low	2	DrvL
3	PT1 Pipe Supply	Red	Temperature Sensor Pipe	3	PtP
4	PT1 Pipe Sense	Pink	Temperature Sensors GND	4	PtG
5	PT 1/2 Common	-	-	-	-
6	Pick-Up left+	Yellow	Pick Up Coil A high	6	PkAH
7	Pick-Up left -	Green	Pick Up Coil A low	7	PkAL
8	Pick-Up right-	Grey	Pick Up Coil B low	8	PkBL
9	Pick-Up right+	White	Pick Up Coil B high	9	PkBH
10 ²	GND	(yel/grn)	Shield	10	PE
11	PT2 Tor. Supply	Orange	Temperature Sensor Torsion	5	PtT
12	PT2 Tor. Sense	-	-	-	-

¹ Connection only necessary for RHE21 construction types E5 and H3 without integrated sensor cable.

² The shield of the cable is connected through terminal 10 to the housing of the RHM. If there is a risk of a significant potential difference between the housing of the RHM and the PE terminal of the RHE, the shield should be connected to the RHE PE connection via a 1nF capacitor. Alternatively, a separate cable can be run for potential equalization between the RHM case and the RHE and the shield left both unconnected and isolated at the RHE or terminated to the PE connection via a 1nF capacitor.

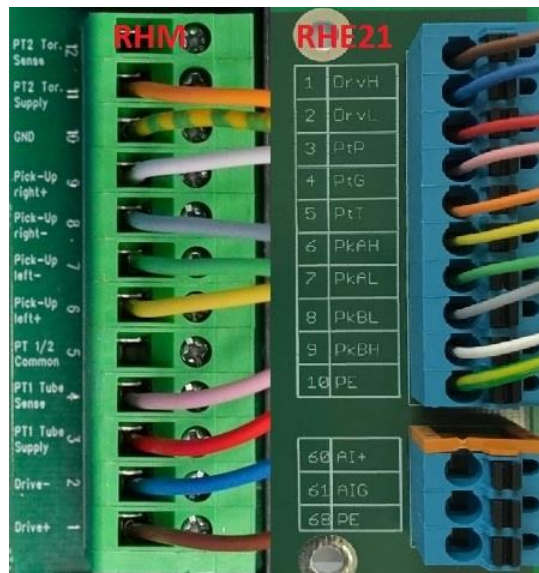

Figure 3: RHE21 Wiring with RHM Connection Types J6 & JO

Upon power up, if the RHE indicates an error and the temperature measurement on the bottom right of the display shows “ -.-°C/°F ” please check the temperature measurement configuration setting in the RHE (section 4.5).

The correct temperature measurement configuration setting for an RHM with connection type JO is “3”.

3.2.1.4 Legacy RHM Sensors (9 Terminals)

Table 5: RHE21 Wiring Plan for RHM legacy version

RHM Terminal		Cable		RHE21 Terminal ¹	
No.	Wire Color	Function		No.	Name
1	Brown	Drive Coil high		1	DrvH
2	Blue	Drive Coil low		2	DrvL
3	Red	Temperature Sensor Pipe Supply		3	PtP
4	Pink	Temperature Sensor Pipe Sense		4	PtG
5	Orange	Temperature Sensors Common		5	PtT
6	Yellow	Pick Up Coil A high		6	PkAH
7	Green	Pick Up Coil A low		7	PkAL
8	Grey	Pick Up Coil B low		8	PkBL
9	White	Pick Up Coil B high		9	PkBH
Screw Term ²	(yel/grn)	Shield		10	PE

¹ Connection only necessary for RHE21 construction types E5 and H3 without integrated sensor cable.

² The shield of the cable is connected to the housing of the RHM using a screw terminal in the junction box. If there is a risk of a significant potential difference between the housing of the RHM and the PE terminal of the RHE, the shield should be connected to the RHE PE connection via a 1nF capacitor. Alternatively, a separate cable can be run for potential equalization between the RHM case and the RHE and the shield left both unconnected and isolated at the RHE or terminated to the PE connection via a 1nF capacitor.

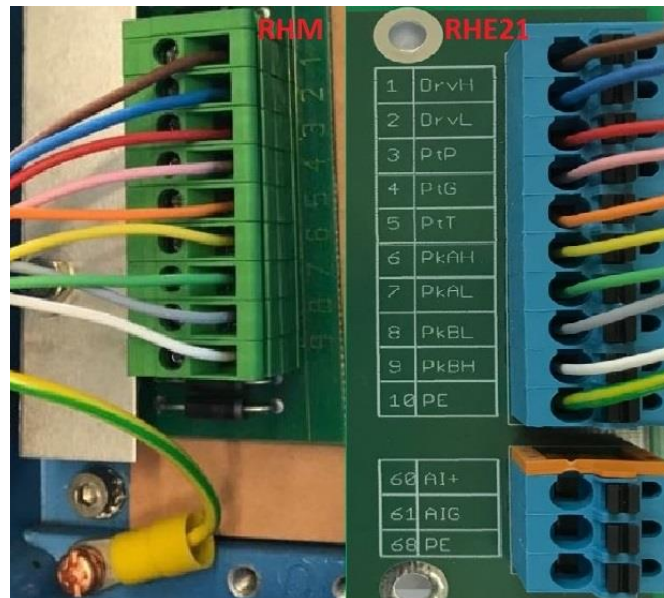

Figure 4: RHE21 Wiring with RHM legacy Sensors

Upon power up, if the RHE indicates an error and the temperature measurement on the bottom right of the display shows “-.-°C/°F” please check the temperature measurement configuration setting in the RHE (section 4.5).

The correct temperature measurement configuration setting for an RHM legacy sensor is “1”.

3.2.2 Power Supply, Grounding and I/O Connections Overview

For connections longer than 0.5m shielded cables should be used. For connections longer than 3m, additional ferrite filter beads close to the RHE are recommended for avoiding RF EMI.

The power supply input is protected by a fuse. As a protection against fire in case of a short in the cable, the supply side of the cable should be protected by a fuse (see figure 7, SI1) with a rating not higher than the current carrying capacity of the cable.

For RHE21 construction types E* the power supply and I/O connections are located in the terminal box shown in Figure 5. The available I/O connections depend on the I/O configuration option of the RHE21.

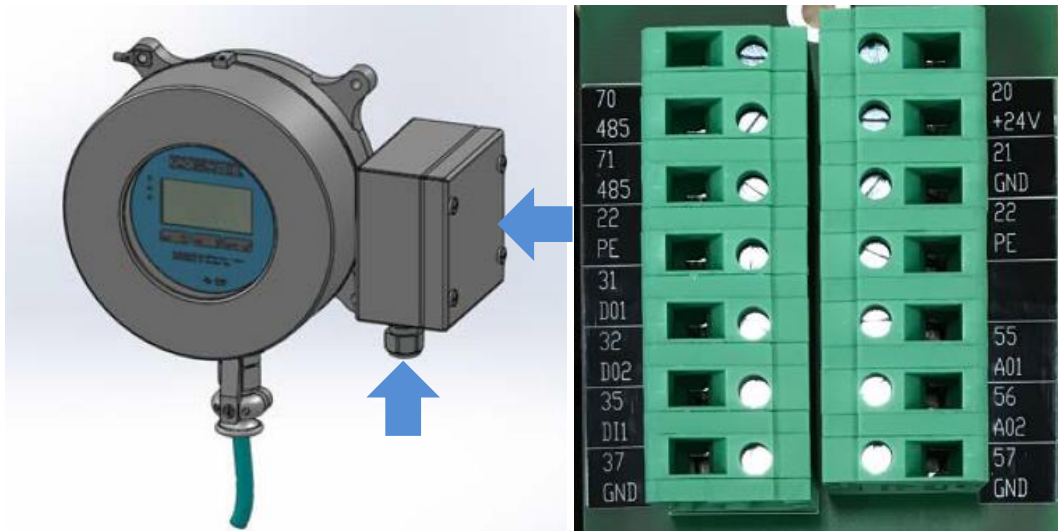

Figure 5: RHE21 Types E* with Terminal Box for Power Supply, I/O Connection and optional Layout

For RHE21 construction types H* the power supply and I/O connections are located in the housing of the transmitter as shown in Figure 6. The upper part of the housing has to be screwed off for connection and the wires must be put through the two cable entries using suitable cable glands.

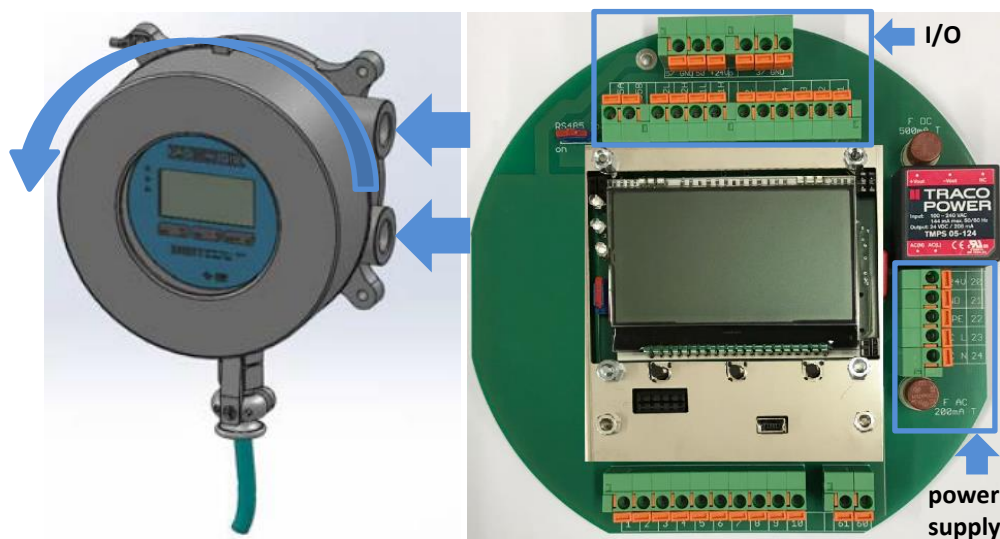

Figure 6: RHE21 Types H* with integrated Connectors for Power Supply and I/O Connection

Depending on the I/O configuration (please see section 7 for further information) of the RHE21 only a limited number of I/O and power supply connections are available. Table 6 lists all I/O and power supply connections.

Table 6: I/O and Power Supply Connections

Terminal No.	Function	Availability
20	Power Supply	+24V RHE21-**D1,U1-****-****-***
21		GND RHE21-**D1,U1-****-****-***
22		PE all versions
23		L RHE21-**A1,U1-****-****-***
24		N RHE21-**A1,U1-****-****-***
31	Digital I/O	DO1 all versions (except i* versions)
32		DO2 RHE21-****-**S1,P1-****-***
40		DO1 C RHE21-****-**i1,i2,i3,iH-****-***
41		DO1 E RHE21-****-**i1,i2,i3,iH-****-***
42		DO2 C RHE21-****-**i1,i3-****-***
43		DO2 E RHE21-****-**i1,i3-****-***
35		DI1 all versions (except i* versions)
37		GND all versions (except i* versions)
50	Analog 4-20mA Output	+24Vo RHE21-E****-**P1-****-*** RHE21-H****-****-****-***
51		AO1H RHE21-****-**P2,PH,CH,i1,i2,i3,iH-****-***
52		AO1L RHE21-****-**P2,PH,CH,i1,i2,i3,iH-****-*** RHE21-H****-**S2,SH-****-***
53		AO2H RHE21-****-**P1,P2,PH,CH,i2,iH-****-***
54		AO2L RHE21-****-**P1,P2,PH,CH,i2,iH-****-*** RHE21-H****-**S1,S2,SH-****-***
55		AO1 RHE21-E****-**S2,SH-****-***
56		AO2 RHE21-E****-**S1,S2,SH-****-***
57		GND RHE21-****-**S1,S2,P1,SH-****-*** RHE21-H****-****-****-***
60	Analog 4-20mA Input	AI+ RHE21-E5,H3**-**CH-****-***
61		AIG RHE21-E5,H3**-**CH-****-***
68		PE RHE21-E5,H3**-**CH-****-***
70	RS485 Interface	RS485A all versions
71		RS485B all versions



The cables used for power supply and grounding must comply with the national requirements. If required, certified cables must be used. The minimum cross section is 0.35mm² (AWG 22) for DC supply cables and 0.5mm² (AWG 20) for mains supply cables.

The RHE21 do not contain a mains switch. A switch or circuit breaker close to the RHE21 must be included in the supply line. The switch must be marked correspondingly.

3.2.2.1 Grounding

RHE21 transmitters must be grounded. Ground the RHE by either connecting a ground to terminal 22 (PE) or to the M4 screw type terminal on the left lower mounting flange. The cross-sectional area of the grounding wire must be equal to or larger than the conductors used for any supply or I/O connection.

Note: National and Local electrical code requirements may contain additional grounding requirements. Please ensure that all grounding is carried out to these [legal] requirements.

3.2.2.2 12V to 24V DC Power Supply

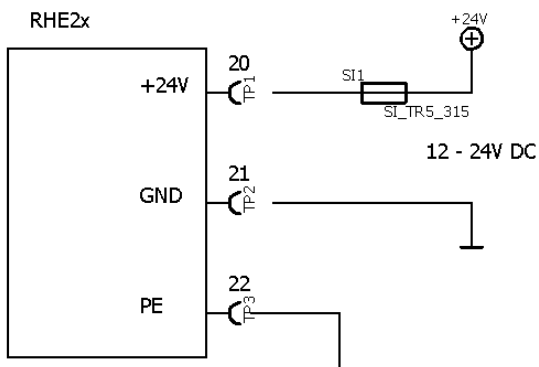

Figure 7: DC Power Supply

Units for use with a DC power supply (order code options D1 and U1) require a regulated DC supply voltage of 12V or 24V. They will operate with a power supply in the range 10V to 28V.

Connect the positive supply to terminal 20 and 0V to terminal 21.

Terminals 21 (0V) and 22 (PE) are connected via a 1kΩ resistor. The resistor can withstand a potential difference of up to 30V between 0V and PE, but voltage differences above 5V should be avoided.

3.2.2.3 100V to 240V AC Power Supply

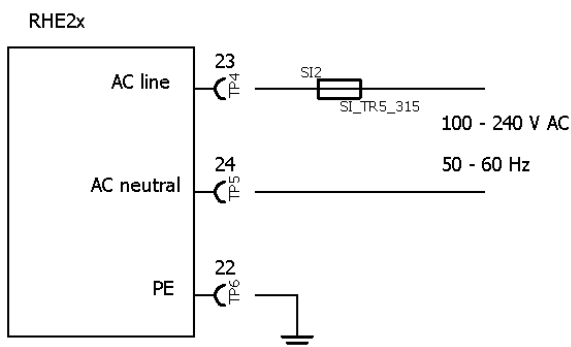

Figure 8: AC Power Supply

Units for use with an AC power supply (options A1 and U1) will operate with any AC supply with nominal 100V to 240V, 50Hz to 60Hz. Voltage limits are 90V to 264V.

Connect the live or hot wire (L) to terminal 23 and the neutral wire (N) to terminal 24.

The AC supply terminals are completely isolated from PE (terminals 10, 22, 68) and GND (terminals 21, 37, 57).

3.2.2.4 AC and DC Supply

Units with power supply option U1 (only available for construction type H*) can be operated from both DC and AC power supplies. Both can be connected simultaneously and the RHE will be powered up as long as one of the supplies is present and within operating tolerance.

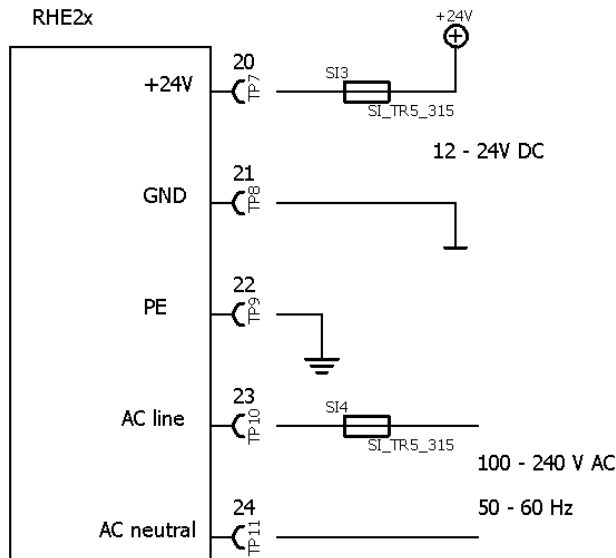

Figure 9: Universal Power Supply

The U1 power supply option is designed to be used where, for instance, battery backup of the flow meter is required.

Connect an AC supply to terminal 23 and 24 (see section 3.2.2.3) and a DC supply to terminals 20 and 21 (see section 3.2.2.2).

If both power supply options are connected, avoid a DC supply voltage higher than 23V to ensure that the AC power supply is used. If the AC supply is disconnected, the DC supply will be used to power the RHE until the Voltage present drops below 10V.

An RHE/RHM flow meter has a typical power consumption of around 3W. If a 12V / 100Ahr battery is used as the DC input to the RHE, the unit would operate for more than 10 days after the AC supply had been disconnected.

3.2.3 Control Inputs and Outputs

In general, shielded cables should be used for cable connections longer than 0.5m. For cable connections longer than 3m, it is recommended that ferrite filter beads are installed close to the RHE terminations to help avoid RF EMI.

3.2.3.1 Digital Outputs

3.2.3.1.1 Non intrinsically safe Digital Outputs

The RHE21 can be supplied with up to two digital outputs.

Outputs DO1 and DO2 are universal outputs and can be used as frequency, pulse, or control/status outputs.

Outputs DO3 and DO4 are control/status outputs only.

Digital outputs are push-pull outputs compliant to IEC 60946. They can drive loads connected to ground and loads connected to +24V.

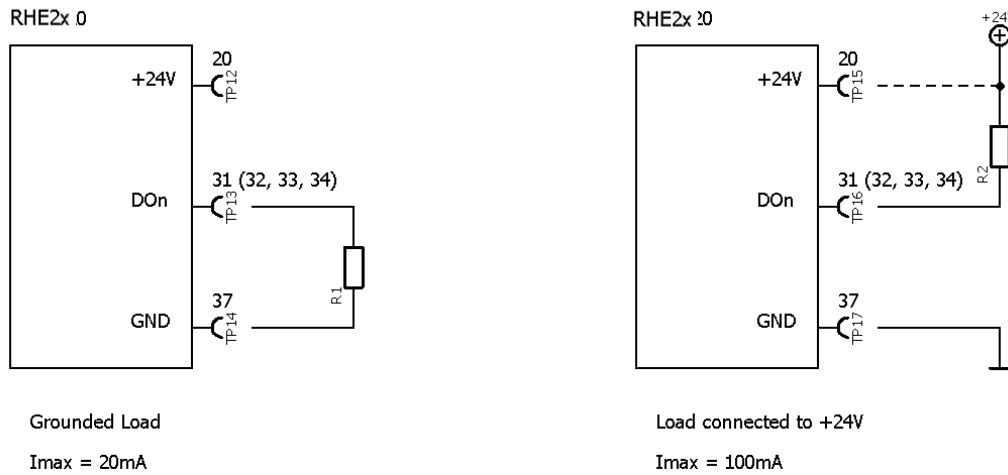

Figure 10: Digital Outputs

Connect the output of the RHE to the load. Connect the other side of the load to either GND or to the positive supply rail. With a grounded load, the output current should be limited to 20mA (480mW at 24V). With a load connected to the positive supply rail the output can drive up to 100mA (2.4W at 24V).

The output can drive relays directly as well. Relays should be connected between the output and the positive supply rail.

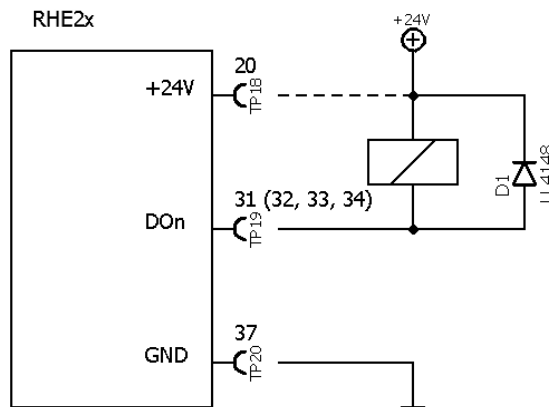

Figure 11: Digital Output with Relays

3.2.3.1.2 Intrinsically safe Digital Outputs

NOTE: Intrinsically safe I/O circuits must only be operated with certified barriers or isolating amplifiers

The RHE21 can be supplied with up to two intrinsically safe digital outputs.

Outputs DO1 and DO2 are universal outputs and can be used as frequency, pulse, or control/status outputs.

As a standard the outputs are floating open collector outputs.

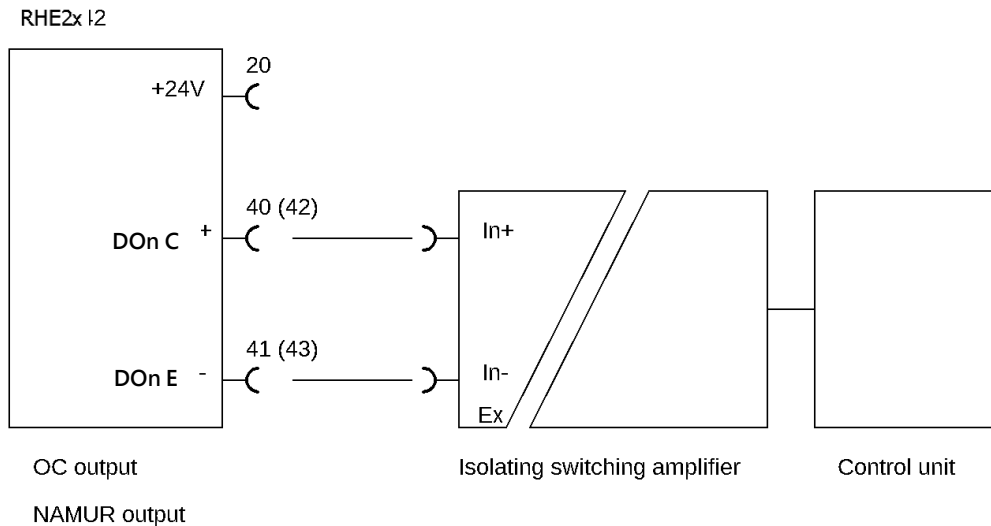

Figure 12: Intrinsically Safe Digital Outputs

Connect the output of the RHE to the isolating switching amplifier.

If an open collector output of the RHE21 is connected to a NAMUR isolating switching amplifier, it might be recommended to disable the short / open supervision of the amplifier.

3.2.3.2 Analog Outputs

3.2.3.2.1 Non intrinsically safe Analog Outputs

RHE21-H*:

An RHE21-H* transmitter can be supplied with up to two 4-20 mA analog outputs. The outputs can be connected in a passive/floating configuration or as active outputs for ground referenced loads.

Output 1 can optionally be equipped with a HART digital communications interface.

For a floating output connect terminal 51 (53 for output 2) to the positive supply rail and terminal 52 (54 for output 2) to the input of local display/PLC/supervisory control system etc.

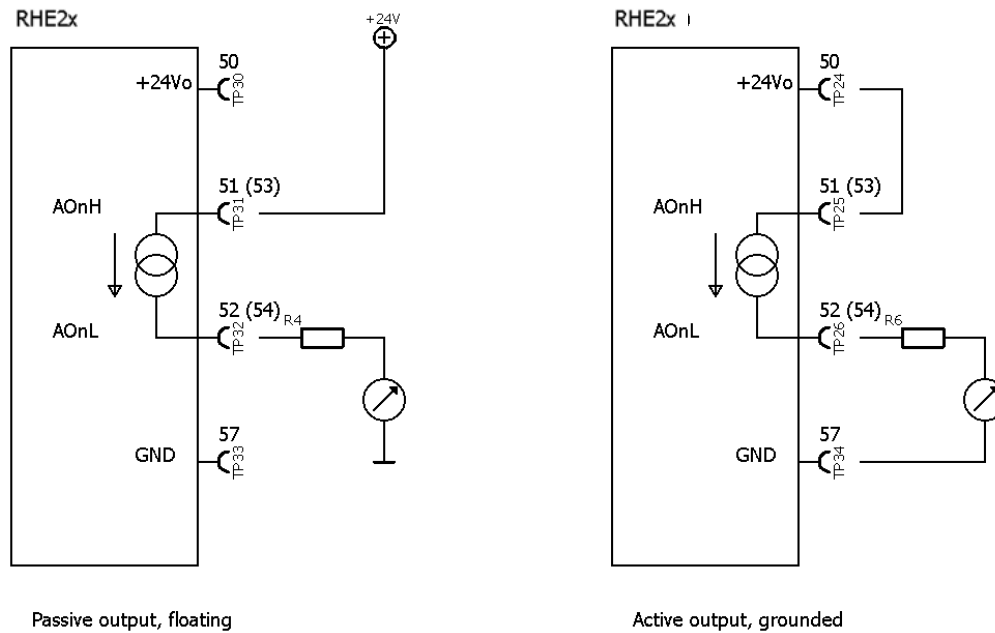

Figure 13: RHE21-H* Analog Outputs

For an active output connect terminal 51 (53 for output 2) to terminal 50 and connect the load between terminal 52 (54 for output 2) and terminal 57.

A protective resistor can be connected in series with the transmitter output and the load. Please note, with a 24Vdc supply, the maximum total load resistance is 600 Ω .

For analog outputs with HART communication, a load resistance of 250 Ω is recommended.

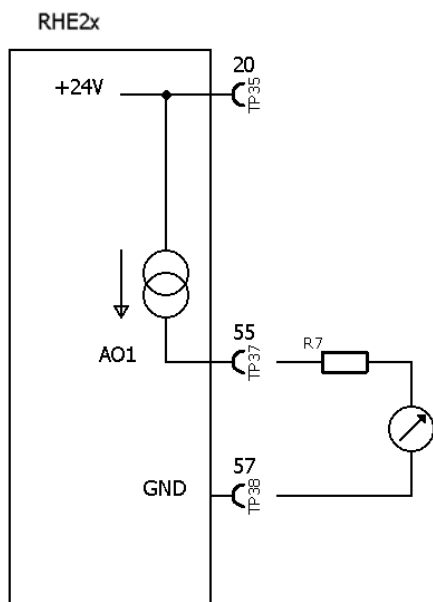

Figure 14: RHE21-E*, active Analog Output

RHE21-E*:

The RHE21-E***-***S* have 1 or 2 active, grounded analog outputs according to Figure 14. Units with I/O version S1 have output AO2, terminal 56. Units with I/O version S2 or SH have 2 outputs, output AO1 (terminal 55) and AO2 (terminal 56). Connect the load as shown between terminal 55 and 57 or 56 and 57.

The RHE21-E***-***P1 have 1 passive floating analog output AO2 (terminals 53 and 54) which also can be wired as active grounded output according to Figure 13, as described above.

The RHE21-E***-***P2, -***PH and -***CH have 2 passive floating analog outputs AO1 (Terminals 51 and 52) and AO2 (terminals 53 and 54). Connect the outputs according to Figure 13, left drawing. A connection for active operation according to the right drawing is not possible as those RHE21 do not provide terminal 50.

A protective resistor can be connected in series with the transmitter output and the load. Please note, with a 24Vdc supply, the maximum total load resistance is 600 Ω .

For analog outputs with HART communication, a load resistance of 250 Ω is recommended.

3.2.3.2.2 Intrinsically safe Analog Outputs

NOTE: Intrinsically safe I/O circuits must only be operated with certified barriers or isolating amplifiers

An RHE21 transmitter can be supplied with up to two passive floating 4-20 mA analog outputs.

Output 1 can optionally be equipped with a HART digital communications interface.

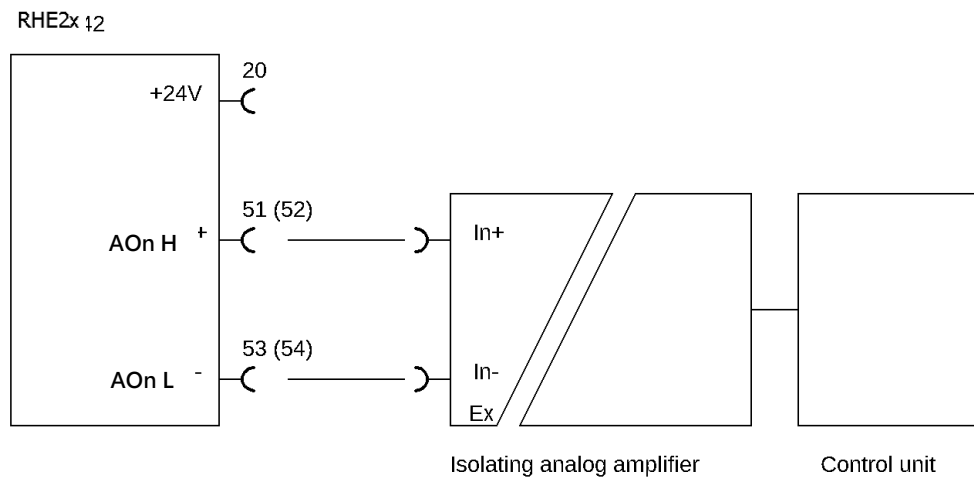

Figure 15: RHE42 Intrinsically Safe Analog Outputs

Connect the output of the RHE to the isolating switching amplifier.

For analog outputs with HART communication, a HART transparent isolating amplifier must be used.

3.2.3.3 Digital Inputs

RHE21 transmitters are equipped with one IEC60946 compliant digital input.

NOTE: Unless advised in advance of delivery, all digital inputs are configured by default for active high operation at the factory. Units with active low operational inputs are available upon request.

The digital input has an input resistance of 24 k Ω and when operated, will draw approx. 1mA when connected to a 24Vdc supply.

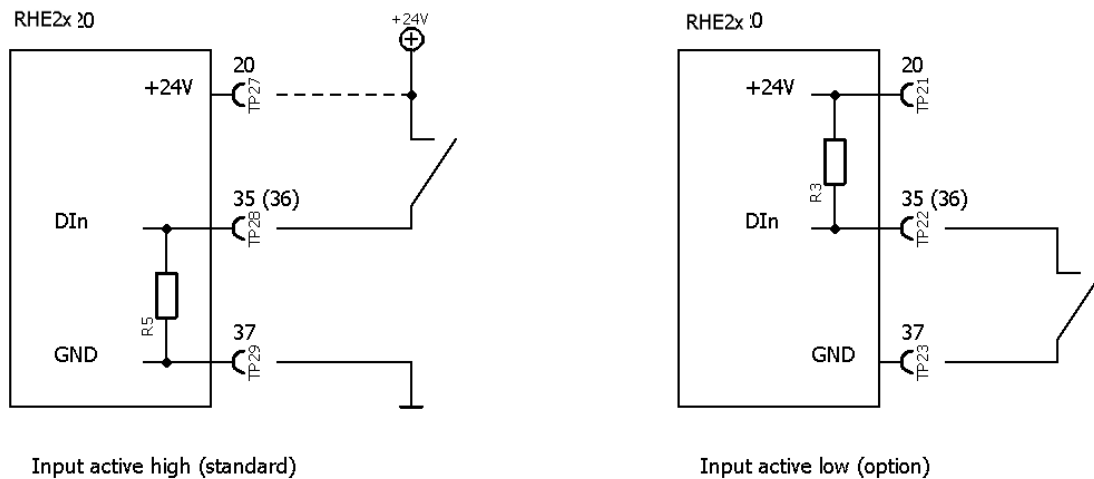

Figure 16: Digital Inputs

The digital input can be operated with an active DC signal instead of a switch. The maximum input voltage must not exceed 30V DC. Note that inputs require a switching current of 0.6mA; the minimum input voltage for a high reading is 14.4V DC.

3.2.3.4 Analog Input

The RHE21-E5 or RHE21-H3 can be equipped with a 4-20 mA analog input for connecting an external transmitter (such as a pressure sensor) with a passive 4-20 mA output. The RHE21 transmitter provides power to the connected devices' output.

The 4 – 20mA analog input is connected to terminal 60 (positive) and terminal 61 (negative) in the bottom terminal box. It is highly recommended to use a shielded cable and that the shield is connected to terminal 68 (PE) at the transmitter.

The analog input in RHE21 transmitters is certified for use with an external transmitter in a hazardous area which includes a certified barrier circuitry for connection with an intrinsically safe device.

The negative (AIG) terminal of the input is internally connected to PE, so it is important to connect only devices that are floating.

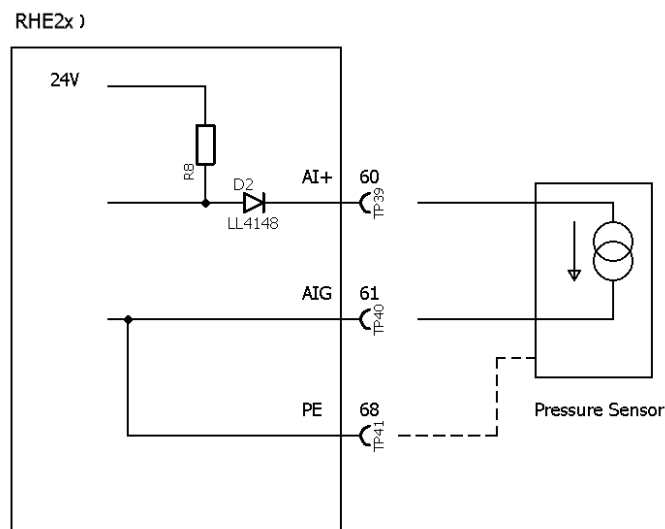

Figure 17: Analog Input

4 Operation and Configuration

RHE2X transmitters can be interrogated and configured in one of three ways:

- 1) Manually through the front panel user interface

Each RHE2X transmitter has a user operation interface consisting of a color LCD screen and three pushbuttons. The screen and pushbuttons are used to navigate through a hierarchical menu structure that logically and intuitively organizes the various features and functions available within the programming set supplied with the instrument. This chapter gives a short introduction into operation of the RHE21 through the front panel user interface. For more detailed information, please refer to the RHE2X Desktop Reference Manual.

- 2) By RHECom PC software through the RS485 serial port

See Chapter 5 for details

- 3) Through Modbus commands via the RS485 serial port

See Chapter 5 for details

4.1 Function of the Pushbuttons

RHE2X transmitters are operated through three front panel pushbuttons. These are labeled “ESC” [X], “NEXT” [>], and “ENTER” [✓]. The function of these pushbuttons depends upon the currently displayed screen.

The following table details button function in specific situations.

Table 7: Functions of the Pushbuttons

Button	Situation	Function
ESC	Menu Navigation	Navigates to the menu one level up
	Number Input	Exits number input field and returns to the associated menu window without saving any changes
NEXT	Menu Navigation	Selects the next menu item
	During Number Input	Increments the number at the cursor position by one. Number increment is circular: a ‘9’ increments to ‘0’ for decimal numbers, ‘F’ increments to ‘0’ for hexadecimal numbers (used for service password)
	Number Sign Change	Changes ‘+’ to ‘-’ and vice versa. When entering a number with a sign character, the cursor will start at the first number character to the right of the sign character in the field. In order to reach the sign character, it is necessary to traverse all the way to the rightmost character and then start at the beginning of the input field again
	Decimal Point Position Change	Shifts the decimal point and cursor position one place to the right
	End of input line	The entire number will flash upon pressing ENTER at the rightmost character in an input field. Pressing NEXT when the field is flashing will return the cursor to the start of the input line
ENTER	Menu Navigation	Navigates to the menu one level down or enters an input screen
	During Number, Sign or Decimal Point entry/change	Moves the cursor one character to the right in an input field. Note that when a number is entered that is not in the parameters’ acceptable range, the field will change to inverse colors (light on dark instead of dark on light). When a number is not within an acceptable range, pressing ENTER at the rightmost character in the field will return the cursor to the leftmost position in the field for re-editing.
	Number Input at the End	Pressing ENTER at the rightmost character in the field will cause the entire field to flash. Pressing ENTER again will commit the modified number and return display to the associated menu window

Button	Situation	Function
	Status Infos - Bit Status Displays	Increment the index of individual bits in the status words. Successively pressing ENTER in the Error Status, Soft Error Status, or Warnings items will allow display/read of each individual bit value and its status description

For example, and as depicted in Figure 18, when navigating the menu structure, press the ENTER pushbutton once to get from the main display screen to the top level menu selection. Press the NEXT button repeatedly to scroll through the entire menu. To enter any specific menu, press ENTER.

Figure 18: Example - RHE21 Top Level Menu Selection

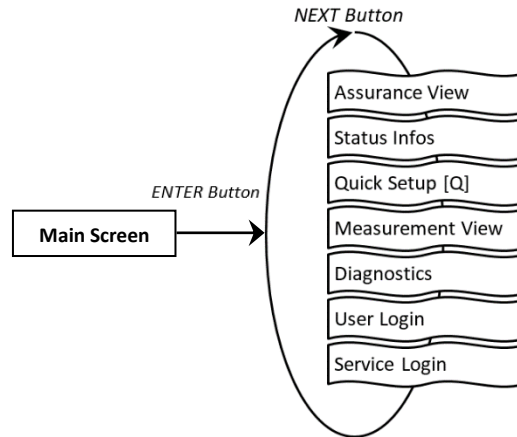

4.2 Passcodes and Menu Selection

To configure and carry out certain functions in an RHE21 transmitter, it is necessary to enter a predetermined passcode. Passcodes protect configuration setup and prevent inadvertent changes to the flow meter operating condition. There are two different access levels with separate passcodes: “USER” and “SERVICE”. The USER level accesses those functions that relate to the operation of the flow meter on a day-to-day basis i.e. zeroing and totalizer reset. The SERVICE level allows access to configuration and setup functions such as I/O ranging and calibration.

When needed, the screen will prompt for a passcode. Passcodes are entered using the NEXT and ENTER buttons. Once entry is complete, the entire passcode will flash. Press ENTER again to enter the menu. If the passcode supplied is incorrect, the cursor will return to the leftmost character of the passcode for re-entry.

Factory default passcodes are shown in Table 8. The USER level passcode can be changed by accessing the “Service Login” menu.

Table 8: Default Passcodes

Access Level	Passcode
User	1111
Service	5678

4.3 Zero Offset Calibration

Before carrying out a zero-offset calibration, make sure that there is a zero flow condition in the RHM sensor i.e. valves have been closed upstream and downstream of the RHM meter body.

Navigate to the “Zero Now” menu item as shown in Figure 19 to perform the zeroing procedure. It will be necessary to enter the user passcode (see section 4.2).

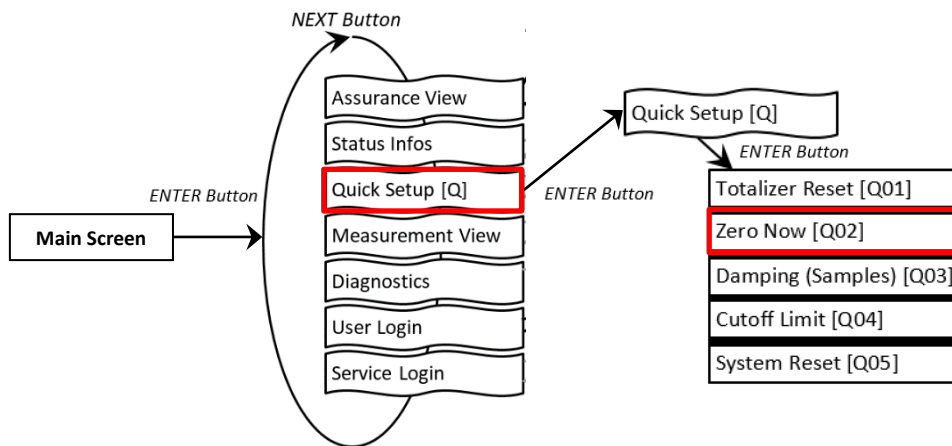

Figure 19: RHE21 Menu - Zero Offset Calibration

To perform the zeroing procedure, press NEXT at the Y/N confirmation screen to change the “N” to “Y”. Press ENTER to start the procedure or ESC to cancel. Once started, a countdown timer will begin. When it reaches 0, the zero offset calibration procedure is complete. Return to the main screen by pressing the EXIT pushbutton twice.

4.4 Change of Positive Flow Direction

Rheonik mass flow meters are bi-directional and can operate with flow passing through them in any direction. In some cases, after installation, the transmitter may read negatively because of orientation. In this case, the flow direction indication can be reversed within the transmitter. To change the positive flow direction, navigate to the “Phase Measurement” menu item under Service Login (Figure 20).

Change the value of the “PhsFlwDirConfig” parameter from “0” to “1” (or vice versa) to change the flow direction indication of the transmitter.

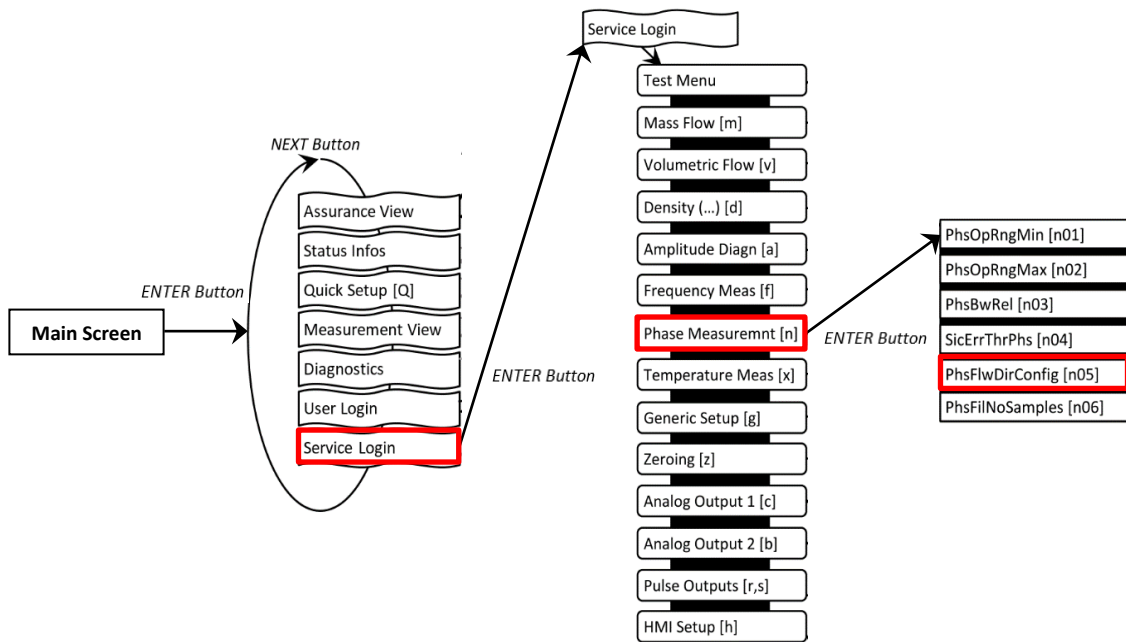

Figure 20: RHE21 Menu - Flow Direction Change

4.5 Temperature Measurement Configuration

For proper performance, it is important to ensure that the correct RHM temperature measurement type is properly configured in all RHE2X transmitters. For new RHE/RHM systems, the temperature measurement type will have already been configured at the factory. Checking that the setting is correct, or to change the setting so the transmitter can be used with a different RHM flow meter body requires accessing the temperature measurement configuration menu item as shown in Figure 21.

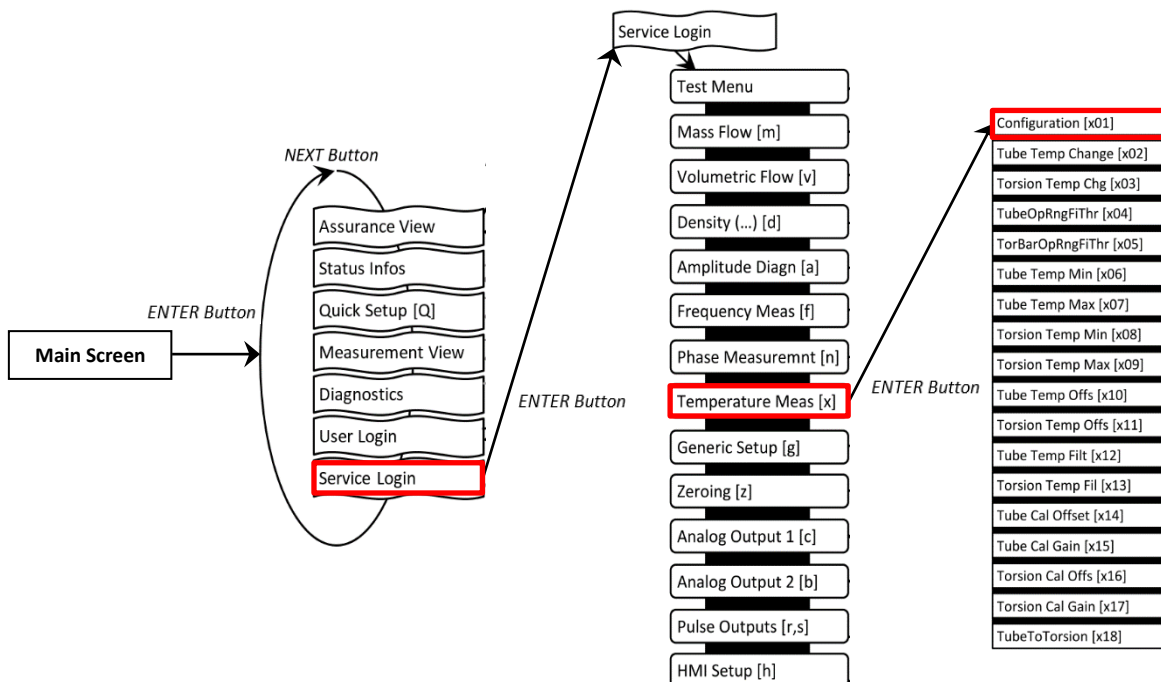

Figure 21: RHE21 Menu - Temperature Measurement Configuration

The value of this menu item will be a number between 0 and 7. Details of the correct setting for this parameter are provided below each of the various wiring schemes found in section 3.2.1.

SERVICE access level passcode is required to access the temperature configuration menu.

4.6 Output Configuration

To configure the analog and digital outputs, navigate to the respective menu items under User Login (Figure 22).

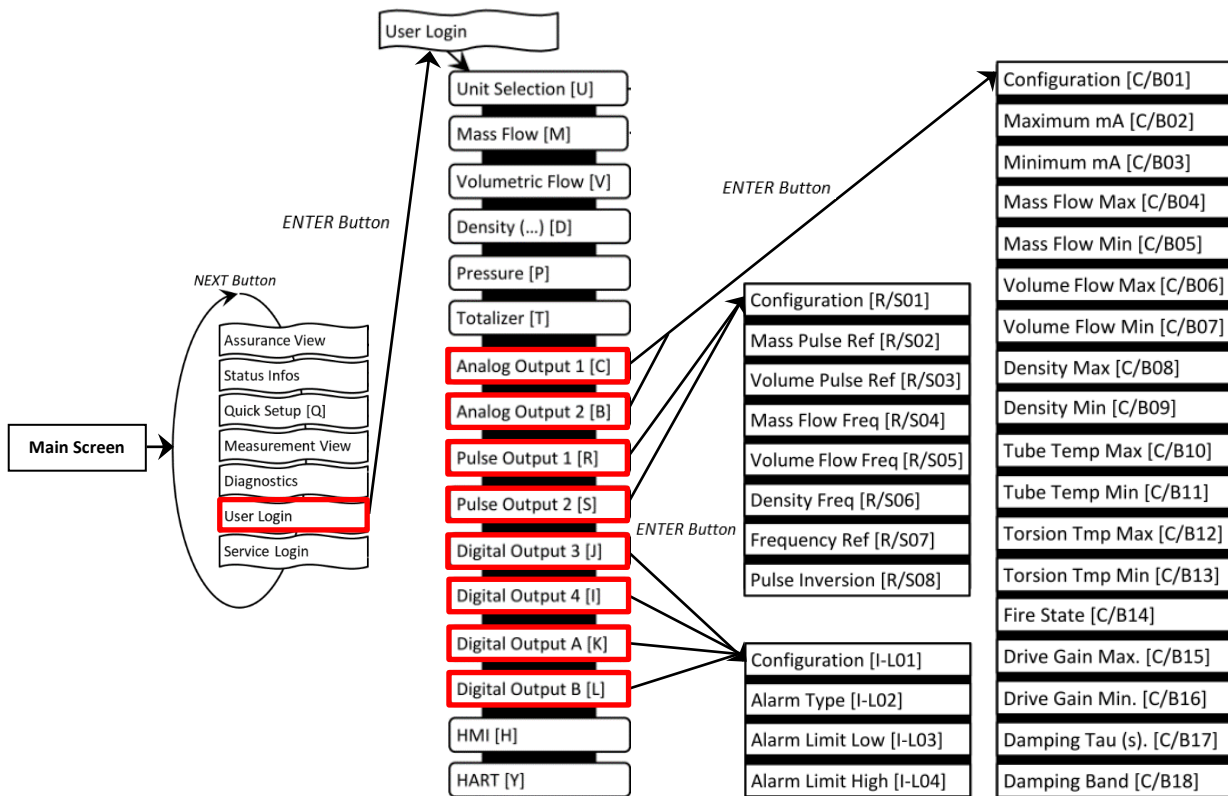

Figure 22: RHE21 Menus - Output Configuration

4.6.1 Analog Output Configuration

1. Select “Analog Output” 1 [C] or 2 [B] and press “ENTER” [✓] to get to the “Configuration” [C/B01] menu
2. Select one of the options stated in Table 9 under ID [C/B01], e.g. Configuration 3 – Density
3. The default settings are: “Maximum mA” [C/B02] = 20mA; “Minimum mA” [C/B03] = 4mA. This can be changed if necessary
4. Assign the maximum and minimum of the measured variable to respective mA level, e.g. 1200 kg/m³ for “Density Max” [C/B08] and 0 kg/m³ for “Density Min” [C/B09]
5. Select a fire state configuration [C/B14] to determine what shall happen if the measured variable range is exceeded or in case of error condition
6. If necessary set a damping factor [C/B17] and damping band range [C/B18]



If the RHE21 is equipped with only one analog output use “Analog Output 2 [B]” for configuration.

Table 9: Important analog Output Parameters

ID	Abbreviation	Full Name / Description
[C/B01]	CurOutConfig	Current Output Configuration: Assigns an output channel to the current output: 0 – Analog output is off. 1 – Analog output is configured for Mass Flow (default). → set [C/B04], [C/B05] 2 – Analog output is configured for Volumetric Flow. → set [C/B06], [C/B07] 3 – Analog output is configured for Density. → set [C/B08], [C/B09] 4 – Analog output is configured for Tube Temperature. → set [C/B10], [C/B11] 5 – Analog output is configured for Torsion Bar Temperature. → set [C/B12], [C/B13] 6 – Drive Gain. → set [C/B15], [C/B16]
[C/B14]	CurOutFireState	Current Output Fire State: Determines the behavior (“fail high” or “fail low”) and value of the analog output when the measured variable range is exceeded (values 1 to 5), i.e. the measurement is outside of (CurOutCurMax) and (CurOutCurMin), or an error condition exists in the SoftError or ErrorStatus fields (values 6 to 10). State 0 - Output tracks the signal and clamps at the CurOutMaxCur and CurOutMinCur values when its range is exceeded (default). State 1 - 22 mA = range exceeded State 4 - 3.2 mA = range exceeded State 5 - 3.6 mA = range exceeded State 6 - 22 mA = error condition State 9 - 3.2 mA = error condition State 10 - 3.6 mA = error condition
[C/B17]	CurOutDampingTau	Current Output Damping Tau: Time constant (Tau) of the current output damping in seconds. An exponential damping mechanism is used within a defined band, see CurOutDampingBand. When the output values leave the defined band the damping is disabled. A value of 0.0 disables the damping.
[C/B18]	CurOutDampingBand	Current Output Damping Band: Defines the band range for the damping of the current output in percent of the range between “Minimum mA” [C/B02] and “Maximum mA” [C/B03]. A value of 100 makes sure that the values never leave the band and that the damping always is active.

4.6.2 Digital Output Configuration

1. Select “Pulse Output” 1 [R], 2 [S] or “Digital Output” 3 [J], 4 [I], A [K], B [L] and press “ENTER” [✓] to get to the “Configuration” [R/S01, I-L01] menu.
 The pulse outputs can be assigned to a certain pulse rate from a measured value, e.g. the mass flow rate.
 The digital outputs [I-L] can be used to indicate status or error.



“Pulse Output” 1 [R] and/or 2 [S] must be disabled if the parameters “Digital Output” A [K] and/or B [L] are assigned to universal digital/pulse outputs

2. Select a configuration for the pulse output according to the options stated in Table 10 under ID [R/S01] or for the status output under ID [I-L01]

Examples:

- a) Configuration of pulse output [R, S] for mass:
 - Select value 1 for parameter ID [R/S01]
 - Acc. to Table 10, the parameter [R/S02] has to be selected. This parameter specifies the mass equivalent to one pulse. E.g. when set to 0.001kg, a mass transfer of 1kg will cause 1000 pulses

- b) Configuration of a frequency output [R, S] for mass flow rate:
 - Select value 7 for parameter [R/S01]
 - Acc. to Table 10 the parameters [R/S04 & 07] have to be selected. The parameter [R/S04] specifies the mass flow rate equivalent to the frequency set under parameter [R/S07]. E.g. when [R/S04] is set to 1kg/min and [R/S07] is set to 1000Hz a mass flow rate of 5kg/min will cause a frequency of 5000Hz

- c) Configuration of a digital output [I-L] for mass flow alarm:
 - Select value 1 for parameter [I-L01]
 - Acc. to Table 10 the parameters [I-L02, 03 & 04] apply. Select the needed alarm type [I-L02] and enter the low [I-L03] and high [I-L04] alarm values. The unit of the alarm is determined by the digital output configuration [I-L01]. For mass flow alarm the unit is fixed to kg/min

Table 10: Important pulse and digital Output Parameters

ID	Abbreviation	Full Name / Description
[R/S01]	VersDigOutCh0/1Config	<p>Versatile Digital Output Configuration: Used to assign different functions to the pulse output. In simple pulse mode, Pulse1 and Pulse2 operate independently. In phase shift mode, Pulse1 and Pulse2 work together to produce the desired pulse output relationship. In phase shift mode, both outputs (Pulse1 & Pulse2) should be set to the same mode.</p> <p>0: Pulse output is off. 1: Mass Flow – Simple Pulse, Forward Flow. → set [R/S02] 2: Volume Flow – Simple Pulse, Forward Flow. → set [R/S03] 3: Mass Flow – Pulse1 & Pulse2 90 Degrees phase shift. → set [R/S02] 4: Volume Flow – Pulse1 & Pulse2 90 Degrees phase shift. → set [R/S03] 5: Mass Flow – Simple Pulse, Reverse Flow. → set [R/S02] 6: Volume Flow – Simple Pulse, Reverse Flow. → set [R/S03] 7: Mass Flow Rate Fast Frequency Output. → set [R/S04 & 07] } fast 8: Volumetric Flow Rate Fast Frequency Output. → set [R/S05 & 07] } response 9: Density Fast Frequency Output. → set [R/S06 & 07] } time 10: Mass Flow Rate Slow Frequency Output. → set [R/S04 & 07] } slow 11: Volumetric Flow Rate Slow Frequency Output. → set [R/S05 & 07] } response 12: Density Slow Frequency Output. → set [R/S06 & 07] } time (1s) 13: Mass Flow Rate RHE Compatibility Mode Frequency Output. } Freq. mode of → set [R/S04 & 07] } previous RHE 14: Volume Flow Rate RHE Compatibility Mode Frequency Output. } → set [R/S05 & 07]</p>

ID	Abbreviation	Full Name / Description
[I-L01]	DigOutCh0/1/A/BConfig	<p>Digital Output Channel 0 Configuration: Alarm Channel configuration: 0: Error indication (default) 1: Mass flow alarm → set [I-L02, 03 & 04] 2: Volumetric flow alarm → set [I-L02, 03 & 04] 3: Density alarm → set [I-L02, 03 & 04] 4: Tube temperature alarm → set [I-L02, 03 & 04] 5: Torsion bar temperature alarm → set [I-L02, 03 & 04] 6: Pressure Alarm → set [I-L02, 03 & 04] 7: Forward Mass Totalizer TotalMassFwd for Batch Mode → set [I-L02, 03 & 04] 8: Forward Volume Totalizer TotalVolFwd for Batch Mode → set [I-L02, 03 & 04] 9: Fatal errors or Zeroing force output low, else high. 10: Fatal errors or Zeroing force output high, else low. For values 1 to 8, the ERR output is pulled high when the alarm condition specified in DigOutCh0/1/A/BAlmType, DigOutCh0/1/A/B AlmLow, and DigOutCh0/1/A/B AlmHigh becomes true.</p>
[I-L02]	DigOutCh0/1/A/BAlmType	<p>Digital Output Alarm Type: Alarm Channel: Digital Alarm Type: 0: Setpoint alarm (hysteresis, default) – Alarm is indicated when the output is higher than DigOutCh0AlmHigh and cleared when it returns below DigOutCh0AlmLow. 1: Inband alarm – Alarm is indicated when the output is in the range from DigOutCh0AlmLow to DigOutCh0AlmHigh. 2: Outband alarm – Alarm is indicated when the output is outside the range DigOutCh0AlmLow and DigOutCh0AlmHigh. An indicated alarm on channel 0 pulls the digital output 4 labeled “ERR” low.</p>
[I-L03]	DigOutCh0/1/A/BAlmLow	<p>Digital Output Alarm Low: Alarm low value, see DigOutCh0/1/A/B AlmType. Must be a floating point value of 0.0 or higher. There is no unit conversion for this register. The unit depends on the DigOutCh0/1/A/B Config setting: 1: kg/min 2: m³/min 3: kg/m³ 4: Degrees Celsius 5: Degrees Celsius 6: Pascal 7: kg 8: m³ The same units are used for all digital status outputs 0, 1, A, and B depending on DigOutCh0/1/A/BConfig respectively.</p>
[I-L04]	DigOutCh0/1/A/BAlmHigh	<p>Digital Output Channel 0 Alarm High: Alarm high value, see DigOutCh0/1/A/BAlmType. Must be a floating point value of 0.0 or higher. See DigOutCh0/1/A/BAlmLow for the unit specification.</p>

4.6.3 Digital Input Configuration

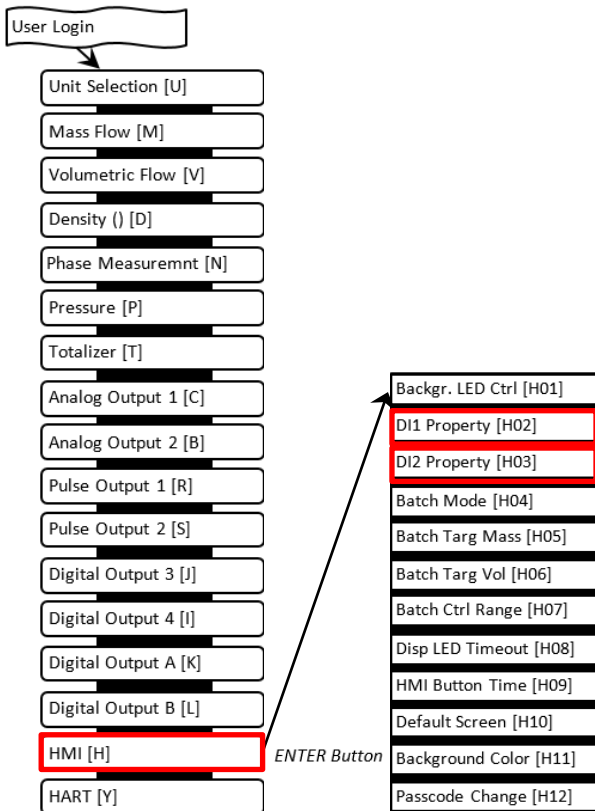

To configure the digital inputs, navigate to the menu item “HMI” under User Login (Figure 23).

1. Select “HMI” [H] and navigate to the “DI1 Property” (digital input 1) [H02] or to the “DI2 Property” (digital input 2) [H03] menu.
2. Select one of the options stated in Table 11.

Figure 23: RHE21 Menu – Digital Output Configuration

Table 11: Digital Input Setting Options

ID	Abbreviation	Full Name / Description
[H02] [H03]	DI1Property DI2Property	<p>Property of Digital Input 1/2: Functionality of Digital Input 1/2:</p> <ul style="list-style-type: none"> 0: DI1/2 is disabled. All inputs are ignored (default). 1: DI1/2 causes the start of a Zeroing Process. Logic is positive – a transition to a high logic level starts the Zeroing. 2: DI1/2 causes the start of a Zeroing Process. Logic is negative – a transition to a low logic level starts the Zeroing. 3: DI1/2 causes reset of the Totalizers and the start of Batch Processing if configured, see RHE2X Desktop Reference, Batch Mode. Logic is positive – a transition to a high logic level starts the Batch. 4: DI1/2 causes reset of the Totalizers and the start of Batch Processing if configured, see RHE2X Desktop Reference, Batch Mode. Logic is negative – a transition to a low logic level starts the Batch. 5: A transition from low to high at DI1/2 stops the totalizers when they are in the running state. A transition from high to low at DI1/2 restarts the totalizers when they are in the stopped state. 6: A transition from high to low at DI1/2 stops the totalizers when they are in the running state. A transition from low to high at DI1/2 restarts the totalizers when they are in the stopped state.

5 Remote Operation

RHE21 transmitters are provided with a RS485 interface for digital communication, remote control and data exchange. An optional HART interface is also available.

5.1 RS485

The RS485 port uses Modbus protocol for permanent connection to a supervisory control system.

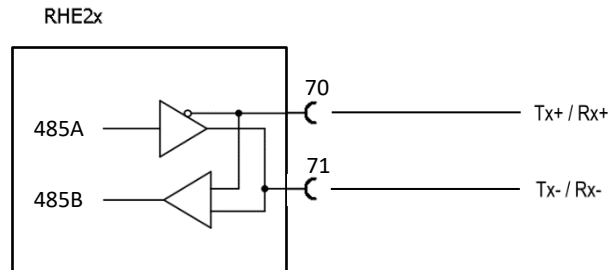

Figure 24: RS485 Interface Wiring

To connect using Modbus via the RS485 serial port, refer to the RHE2X Desktop Reference Manual for a detailed description of the interface and register set.

The RHE21 transmitter features an internal 120 Ω termination resistor with a switch at the back side of the transmitter. Normally, the termination switch (and the factory default position) should be set to ON. When more than one device is attached to the RS485 line this switch must be set to OFF for all devices on the line except for those devices at each end of the line, where the switch must be set to ON.

The termination resistor switch as well as the optionally available hardware lock switch are located in the housing of the RHE21 as shown in Figure 25.



The housing must not be opened with power supply connected.

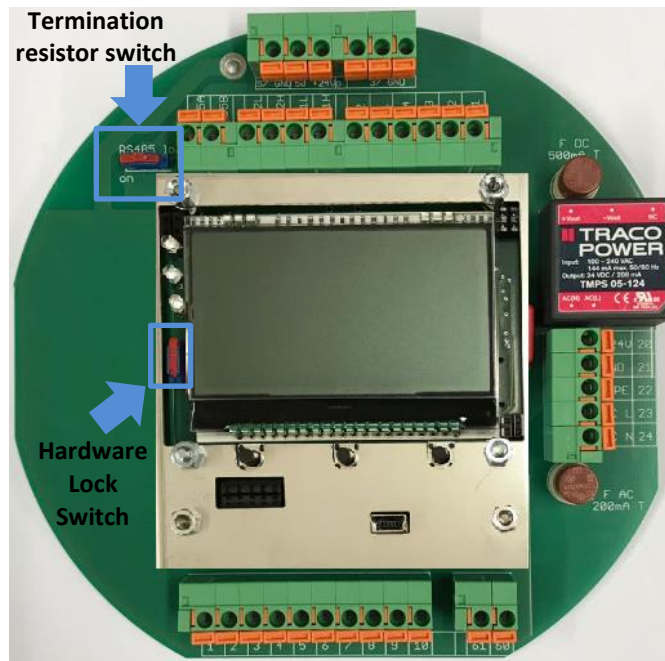

Figure 25: Interior of RHE21 with Termination Resistor Switch and Hardware Lock Switch

5.2 HART

The HART interface is an option offered with the RHE21 transmitter.

Connect the analog output 1 as described in chapter 3.2.3.1.2 to a HART host input. A 250 Ω load resistor is recommended when connecting a HART modem.

For a full description of the available HART register set, refer to the RHE2X HART manual.

6 Service and Maintenance

6.1 Maintenance and Calibration

RHE2X mass flow transmitters and their associated RHM flow sensor do not require any regular maintenance.

Under normal circumstances, RHE2X transmitters and their associated RHM flow sensor should not require flow calibration. If flow calibration is required, either as a one-off check or at prescribed intervals to meet statutory or operational requirements, it can be carried out in one of two ways:

- 1) In the field calibration against reference meter or prover
- 2) At a calibration laboratory

Local regulations or contractual/operational requirements will determine the type and interval of such calibrations. Refer to the RHE2X Desktop Reference for full details on calibrating flow meters using RHE2X transmitters.

Regular checks of the zero-point calibration according to point 6 of section 2 and section 4.3 are recommended to ensure a consistent measurement accuracy within the allowed deviations.

Density measurement in a RHE2X transmitter can be calibrated in the field. Please refer to the relevant section in the RHE2X Desktop Reference for instructions.

6.2 Troubleshooting

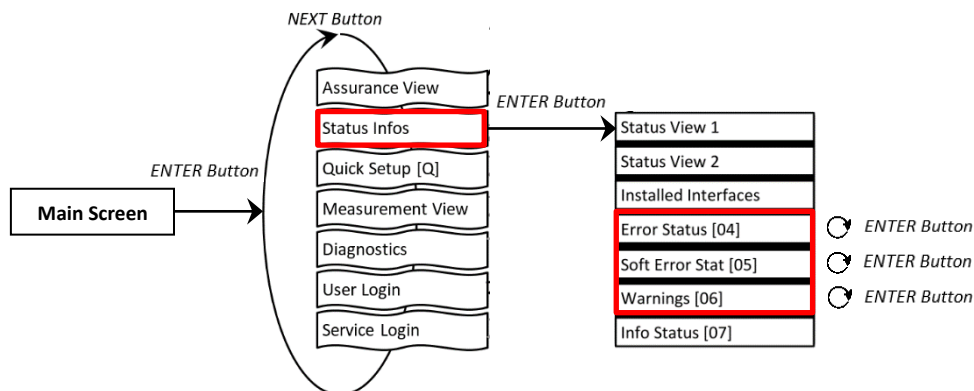

Figure 26: Error / Warning Status

Each status window shows a code e.g. '0x00000000'. By pressing the ENTER button, the cursor walks through this code from right to left. The respective error or warning bit is explained at the bottom of the display.

For detailed assistance, please refer to the troubleshooting section (Chapter 6) of the RHE2x Desktop Reference. This chapter contains comprehensive information on understanding and troubleshooting errors, warnings, and connection issues with the flow meter.

The RHECom software can also be used to read out error codes, please refer to the RHECom quick guide.

6.3 Service

RHE2X transmitters do not contain any user serviceable parts. Please contact your local sales/support agent or Rheonik Support for assistance.

6.4 WEEE and RoHS

RHE21 transmitters are not subject to the WEEE directive and are fully compliant to the RoHS directive.

7 Ordering Code

Construction Type

- E1** Stainl. steel enclosure Exd(e), wall/hook mount, 1* Alu box for I/O with 2* M16 gland Ex e, 3m integral sensor cable
- E2** As E1 but 10m integral sensor cable
- E3** SS316 enclosure Exd(e), wall/hook mount, 1* SS316 box for I/O with 2* M16 gland Ex e, 3m integral sensor cable
- E4** As E3 but 10m integral sensor cable
- EP** As E3 but 10m integral sensor cable and panel mount version
- E5** As E3 but 1* SS316 box for sensor cable with 2* M16 (standard 1* blind + 1* gland. With analogue input 2* gland)
- H1** Stainl. steel enclosure Exd, wall/hook mount, 2* cable entry 1/2" NPT for I/O, 3m integral sensor cable
- H2** As H1 but 10m integral sensor cable
- H3** SS316 enclosure Exd, wall/hook mount, 2* cable entry 1/2" NPT for I/O, 1* SS316 box for sensor cable with 2* M16

Supply Voltage

- D1** 12 to 24 VDC (+/- 10%)
- A1** 100 to 240 VAC (+/- 10%, 48 to 62 Hz)
- U1** 12 to 24 VDC (+/- 10%) and/or 100 to 240 VAC (+/- 10%, 48 to 62 Hz) - only with type H1, H2, H3

Software Function Package

- SO** Standard package: mass with calculated density/volume measurement
- DO** Multifunction package: mass and live density/volume measurement
- AF** As DO plus Assurance Factor® diagnostics suite
- GV** As AF plus API standard volume / net oil / concentration
- CT** As GV plus hardware lock switch function

I/O Configuration

- S1** Standard One - 1*4/20mA active, 2* DO (Pulse/Freq/Status), 1* DI, RS485 (Modbus)
- S2** Standard Two - 2* 4/20mA active, 2* DO (Pulse/Freq/Status), 1* DI, RS485 (Modbus)
- P1** Standard One - 1* 4/20mA passive, 2* DO (Pulse/Freq/Status), 1* DI, RS485 (Modbus)
- P2** Standard Two - 2* 4/20mA passive, 2* DO (Pulse/Freq/Status), 1* DI, RS485 (Modbus)
- SH** HART - as Standard S2 plus HART
- PH** HART - as Standard P2 plus HART
- CH** Premium - as SH plus analogue input - only with type E5, H3

Hazardous Area Approval

- NN** Without (sufficient to operate RHM in ATEX zone 2)
- A5** ATEX/IEC <Ex> (1)G [Ex ia Ga] IIC for RHM in zone 0,1 - RHE in ordinary area
- A2** ATEX/IEC <Ex> II 3(1)G Ex dc ec [ia Ga] IIC T4 Gc - RHE type E* in zone 2
ATEX/IEC <Ex> II 3(1)G Ex dc [ia Ga] IIC T4 Gc - RHE type H* in zone 2
- A1** ATEX/IEC <Ex> II 2(1)G Ex db eb [ia Ga] IIC T4 Gb - RHE type E* in zone 1
ATEX/IEC <Ex> II 2(1)G Ex db [ia Ga] IIC T4 Gb - RHE type H* in zone 1
- CS** CSA US-Can. Class I, Div. 2 - RHM in Div. 1, 2 and RHE in ordinary area (only type H*)
- C2** CSA US-Can. Class I, Div. 2 - RHM in Div. 1, 2 and RHE in Div. 2 (only type H*)
- C1** CSA US-Can. Class I, Div. 2 - RHM and RHE in Div. 1, 2 (only type H*)

RHE21 - [] - [] - [] - [] - NN - NNN

Appendix A Ex-Safety Instructions

A.1 Safety instructions for the installation in a hazardous area:

- The measurement system shall be installed & maintained according to the applicable standards regarding electrical installations in a hazardous area.
- Before installation, carefully read the operating manual of the RHEONIK Coriolis Flowmeter.
- The mounting, electrical installation, commissioning, and maintenance are to be carried out by qualified personal only who are trained in explosion protection.
- All national regulations concerning the installation, maintenance, and repair of instruments in explosion hazardous areas must be observed.
- The sensor cable connection between sensor RHM and the transmitter RHE or the barrier EZB is intrinsically safe. Only the cable delivered by Rheonik may be used. The use of any other cable shall be clarified with Rheonik beforehand.
- For safety reasons the total cable length between a RHM sensor and transmitter RHE or a barrier EZB must not exceed 100 meters.
- The connection cable ARHE-C4 is specified for -50°C to +105°C. Temperatures above must be avoided. Temporary temperatures below -50°C are allowed if the cable is fed in a protecting tube.
- Always close unused cable glands and openings with certified dummy plugs
- When installed in the hazardous area the RHE21 must not be opened with any power connection alive.
- THE USB interface must not be used in hazardous areas.
- In accordance with details indicated on the ex-plate, the equipment may be used under conditions where ignitable atmospheres composed of a mixture of air and other gases, steam or dust are present. The equipment is not suitable for mines.
- The intrinsically safe sensors RHM are available for zone 0, 1 or 2 and for div. 1 and div. 2. Refer to the letter plate of the RHM for the individual classification.
- Regarding the installation of the sensor RHM refer to the corresponding manual.
- Special conditions for CSA certified units:
Warning: Substitution of components may impair intrinsic safety
Avertissement: La substitution de composants peut compromettre la sécurité intrinsèque.
Warning: Do not open when energized!
Avertissement: Ne pas ouvrir sous tension!



Read the manual before connecting or operating the unit!

A.2 System Description:

A Rheonik Coriolis mass flow meter system for hazardous areas consists of a mass flow sensor RHM and a transmitter RHE with built in barrier or of a mass flow sensor RHM, a dedicated barrier EZB and a transmitter RHE without barrier.

The mass flow sensor RHM is intrinsically safe and can – depending on the individual certification – be mounted in zone 0, zone 1 or zone 2. For the American market versions for div. 1 and for div 2 are available.

The RHE21 is an associated equipment and contains the barriers for the RHM to be connected.

Depending on the certification the transmitter RHE21 may be mounted in the following areas:

Code	Mountable in	Certified according / by
A1	zone 1, 2; safe area	ATEX, IECEx
A2	zone 2; safe area	ATEX, IECEx
AS	safe area	ATEX, IECEx
C1	zone 0, 1, 2; div 1, 2; safe area	CSA, for USA and Canada
C2	zone 2; div 2; safe area	CSA, for USA and Canada
CS	safe area	CSA, for USA and Canada

A.3 Electrical Safety Limits

Power supply and I/O (All RHE21 except RHE21-E*D1-I*-A***-***):**

Signal	Terminals	Type	Nominal Voltage	Um
AC supply	23, 24	Supply	90 – 250V AC	250V
DC supply	20,21	Supply	10 – 28V	250V
Supply for analog out	50, 57	Supply out	24V*)	250V
Digital Out	31 - 34	Out	(30V)*	250V
Analog Out	51 - 56	Out	24V	250V
Digital In	35, 36	In	24V	250V
RS485	70, 71	Interface	70 to 71: $\pm 5V$ 70, 71 to PE: 30V**)	250V
USB	(Connector)	Interface	5V	250V

*) A short circuit to any voltage between 0V and 30V should be avoided but will not damage the output.

***) The nominal signal Voltage between 70 and 71 is 3.3V. The interface is floating but clamped to PE with a clamping voltage of 30V.

Power supply and RS485 (Only RHE21-E*D1-I*-A***-***):**

Signal	Terminals	Type	Nominal Voltage	Um
DC supply	20,21	Supply	10 – 28V	30V
RS485	70, 71	Interface	70 to 71: $\pm 5V$; 70 or 71 to PE: 30V**)	30V
USB	(Connector)	Interface	5V	30V

***) The nominal signal Voltage between 70 and 71 is 3.3V. The interface is floating but clamped to PE with a clamping voltage of 30V.

Applied voltages above the nominal voltage may damage the corresponding input or output but will not affect the safety on the connection to the IS RHM or the IS pressure sensor.

Voltages above the Um values must be avoided.

Intrinsically safe I/O terminals (Only RHE21-E*D1-I*-A***-***):**

Circuit name	Terminals	Ui [V]	Ii [mA]	Pi [mW]	Li [mH]	Ci [nF]
4-20mA out	51 – 52, 53 - 54	30	100	750	<0.1	negligible
Digital out	40 – 41, 42 - 43	30	50	375	negligible	negligible
Digital in	46 - 47	30	50	375	negligible	negligible

Intrinsically safe I/O terminals for RHM:

Circuit name	Terminals (E5, H3)	Cable colors (fixed RHM cable)	Uo [V]	Io [mA]	Po [mW]	Lo [mH]	Co [nF]
Drive circuit	1 - 2	Brown - blue	8.1	136	275	1.9*	2000
Temp. sense	3 - 4 5 - 4	Red – pink orange - pink	6.1	45.7**	69.7	1	2000
Pickup circuit	6 - 7 9 - 8	Yellow – green white - gray	2.4	9.0	5.4	100	2000

*) 7.5mH for sensors RHM certified for gas group IIB / group C and D.

***) PtP (Terminal 3) and PtT (Terminal 5) share a common ground PtG (terminal 4). The maximum current on terminal 4 therefor is 91.4mA.

Analog 4-20mA input

Circuit name	Terminals	Uo [V]	Io [mA]	Po [mW]	Lo [mH]	Co [nF]
Current Input	60 - 61	24.7	91.5	565	4.0	100

A.4 Thermal Safety Limits

The RHE21 with Ex-code A1, A2, C1 or C2 have the temperature class T4

The RHE21 with Ex-code AS or Cs must be installed in the safe area, therefore no temperature class is specified for these units.

The ambient temperature must under no circumstances exceed the limits specified in chapter A.10.

A.5 Grounding and Shielding

The RHE21 must be grounded.

The minimum cross section of the ground wire is 2.5mm². Wires with 2.5mm² can be connected to the PE terminal 22 or to the M4 screw type terminal. Wires with a bigger cross section must be connected to the M4 screw type terminal.

Shield between RHM and RHE:

IEC60079-0 recommends to ground shielded cables just on one end, normally outside the hazardous area. On the other side the shield may be grounded via a 1nF capacitor.

In small installations (cable length typically less than 10m) the shield can be grounded on both sides, provided that there is no potential difference between PE at the RHM and PE at the RHE. This can be assumed if there is a good metallic contact or if a dedicated PE cable of at least 4mm² connects the two grounding points.

Most RHM provide a PE terminal and terminal for grounding via 1nF. If there is no capacitive ground, special measures might be required.

Power supply and I/O circuits:

I/O and supply cables should be shielded when fed outside the control cabinet. When unshielded wires are used outside a building, dedicated surge suppressors must be used.

NOTE:

The intrinsically safe circuits for the RHM and for the analog input are connected to earth; along the intrinsically safe circuits potential equalization must exist

A.6 Installation

All cable entries are for fixed installation only. Cables must be clamped to prevent pulling or twisting.

RHE21-E* (ATEX/IECEX only):

The RHE21-E* have 2 cable glands M16x1.5 with a clamping range 4 – 11mm for I/O and power supply.

Options with 2 threads M25 or ½" NPT or ¾" NPT are available upon request. In that case the user is responsible for using correspondingly certified cable glands.

The cable glands or adaptors must not be changed by the user.

RHE21-H*:

The RHE21-H* have 2 threads ½" NPT for I/O and power supply.

For versions with ATEX and IECEx certification the installer must provide the required certified cable glands and blind plugs and is responsible for the safe installation.

For RHE21-H* with CSA certification C1 (div. 1) the installer must provide the required sealing fittings and is responsible for the safe installation.

For RHE21-H* with CSA certification C2 (div. 2) the installer must provide the required cable glands and is responsible for the safe installation.

Cable glands and sealing fittings are available upon request.

Connection to RHM and 4-20mA pressure sensor:

All RHE21 except –E5 and –H3 come with a fixed cable (up to 10m) for connecting the RHM.

RHE21-E5 and RHE21-H3 have a stainless-steel connection box for connecting the cable to the RHM and for the (optional) intrinsically safe 4-20mA input for pressure measuring. This Connection box has 1 (no 4-20mA input) or 2 (with 4-20mA input) cable glands with a clamping range 4-11mm.

Special conditions for CSA certified units

RHE21 marked Class I, Div. 1, Group A, B, C, D and/or Class I, Zone 1, A/Ex db [ia Ga] IIC T4 Gb

1. Shall be installed in class I, Division 1 / Zone 1 location.
2. Unused conduit openings shall be plugged with certified blanking components.
3. Conduit seal shall be installed within 50mm from the enclosure
Un scellement doit être installé moins des 50mm du boîtier.
4. Potential equalization shall be provided along intrinsically safe circuits grounding.

RHE21 marked Class I, Div. 2, Group A, B, C, D and/or Class I, Zone 2, A/Ex nA [ia Ga] IIC T4 Gc

1. Shall be installed in class I, Division 2 / Zone 2 location.
2. Potential equalization shall be provided along intrinsically safe circuits grounding.

RHE21 marked [Ex ia Ga]

1. Shall be installed in ordinary (non-hazardous) location only.
2. Potential equalization shall be provided along intrinsically safe circuits grounding.

A.7 Electrical connection of power supply and I/O

As all I/O and supply terminals of the RHE21 are rated for $U_m = 250V$, there are no special rules for installation.

National and local standards regarding electrical installations must be observed.

For information regarding function and usage of the different I/O and supply circuits refer to the corresponding chapters of the main manual.

The USB interface must not be connected and used in hazardous areas.

RHE21-H*:

The RHE21-H* have internal cage clamp terminals in the XP housing.

Conductor cross-section: 0.2 – 2.5mm²

Stripping length: 6 – 9mm

RHE21-E* (ATEX/IECEX only):

The RHE21-E* have screw type terminals in the Ex e connection box.

Conductor cross-section: 0.2 – 2.5mm²

Stripping length: 6 – 9mm

Torque: 0.4 – 0.5Nm

A.8 Electrical connection to RHM and pressure sensor

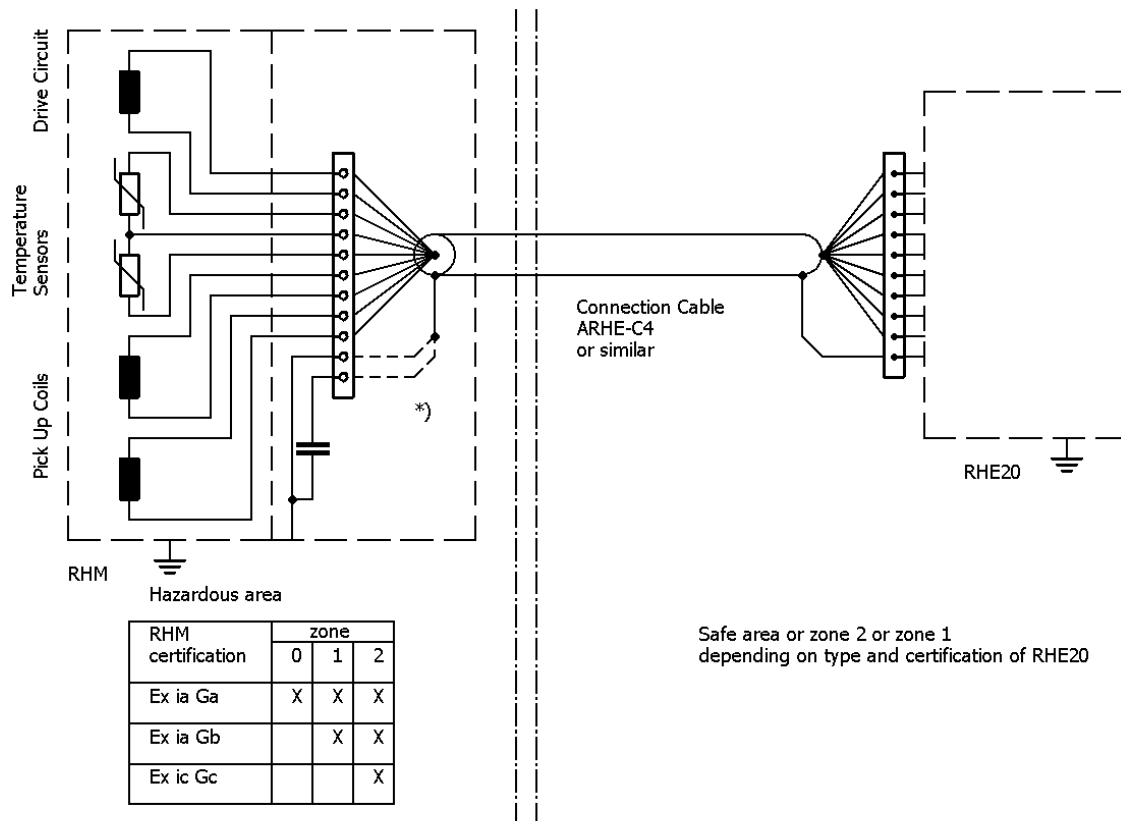

*) connect shield as required to "PE" or to "PE_C"

The figure shows the electrical connections between RHM*** -S* or -J* (connection box) and a RHE21.

A 4-20mA pressure sensor may be connected to terminals 60 (+) and 61 (-) (not shown in the figure).

For further information regarding the connections, the function of the different signals and special connections for RHM with fixed cable, please refer to chapter 4 “Electrical Installation” and to appendix A “Ex-safety instructions” of the RHM manual.

The RHE21-E5 and -H3 have cage clamp terminals for RHM and pressure sensor.

Conductor cross-section: 0.2 – 2.5mm²

Stripping length: 6 – 9mm

A.9 Ordering Code

The following extract of the ordering code shows the information relevant for hazardous areas.

E21-EEPP-SSOO-HHCC-OOO

E21	RHE21	
EE	Housing Options	
	E1, E2 = aluminum connection box, fixed RHM cable, ATEX and IECEx only	
	E3, E4, EP = SS connection box, fixed RHM cable, ATEX and IECEx only	
	E5 = SS connection box for I/O and RHM cable, ATEX and IECEx only	
	H1, H2 = no connection box, fixed RHM cable	
	H3 = connection box for RHM cable	
PP	Power supply options	
	D1 = 12 to 24V DC	
	A1 = 100 to 240V AC	
	U1 = DC plus AC	
SS	SW Options	
OO	I/O Configuration Options	1)
	I* = up to 3 I/O signals (4-20mA out, digital out, digital in), all IS	2)
	All other: up to 8 I/O signals, all non-IS	
HH	Hazardous areas approvals	
	ATEX, IECEx:	
	A1 = II 2(1)G Ex db [ia Ga] IIC T4 Gb	RHE21 in zone 1 or 2, (housing H*)
	II 2(1)G Ex db eb [ia Ga] IIC T4 Gb	RHE21 in zone 1 or 2, (housing E*)
	A2 = II 3(1)G Ex db [ia Ga] IIC T4 Gc	RHE21 in zone 2, (housing H*)
	II 3(1)G Ex db ec [ia Ga] IIC T4 Gc	RHE21 in zone 2, (housing E*)
	AS = II (1)G [Ex ia Ga] IIC	RHE21 in safe area
	CSA (USA and Canada)	
	C1 = class I, Div. 1 / Ex db [ia Ga] IIC T4 Gb	RHE21 in zone 1 or 2, Div. 1 or 2
	C2 = class I, Div. 2 / Ex nA [ia Ga] IIC T4 Gc	RHE21 in zone 2, Div. 2
	CS = [Ex ia Ga] IIC	RHE21 in safe area
CC	Measurement Certifications	
OOO	Special Options	

- 1) All versions provide one RS485 interface, non-IS
- 2) Only housing options E*, power supply D1 and only hazardous areas approvals A*

Not all combinations are possible. For available combinations see instructions.

Where no versions for the place holders are specified, these parameters are not relevant for the Ex-certification.

Where versions are specified (e. g. for "PP Power Supply Options": D1, A1 etc.), versions not listed here are not available with Ex certification.

For the complete ordering code refer to the respective datasheets.

A.10 Technical Data

The following limits are valid for safe operation:

Electrical data:	Refer to chapter A.3 and to the information on the letter plate
Operating temperatures:	-20°C (-40°C) to +60°C (version dependent)
Humidity:	10 to 90% relative humidity, non-condensing
Altitude:	up to 3000m, higher maximum altitude upon request

For the complete technical data refer to appendix B “Technical Data”.

A.11 Compliance

The RHE21 certified according to ATEX / IECEx comply with the following standards for hazardous areas:

IEC 60079-0
IEC 60079-1
IEC 60079-7
IEC 60079-11

For the list of standards relevant for a certain unit and for the release date refer to the certificate.

The RHE21 certified by CSA comply with the following standards for hazardous areas:

C22.2 No 61010-1: 2012
UL 61010-1 3rd Ed.
C22.2 No 30-M1986 (R2012)
UL 1203, 5th Ed.: 2013
C22.2 No 60079-0, 6th Ed.
UL 60079-0, 6th Ed.
C22.2 No 60079-1, 7th Ed.
UL 60079-1 7th Ed.
C22.2 No 60079-11, 6th Ed.
UL 60079-11, 6th Ed.
C22.2 No 213 / ANSI/ISA 12.12.01: 2017
C22.2 No 60529 Ed. 2.2.
ANSI/ISA 60529 Ed. 2.2
C22.2 No. 94.2-07 (R2012)
UL 50E: 2015

For the list of standards relevant for a certain unit and for the release date refer to the certificate.

A.12 Service and repair

The unit does not contain any user serviceable parts and must not be opened by the user.

If the unit gets modified in any way, the Ex-certification gets void.

In case of malfunction connect your dealer or directly Rheonik Messtechnik GmbH

A.13 Contact address

Rheonik Messtechnik GmbH

Rudolf-Diesel-Str. 5

85235 Odelzhausen

Germany

www.rheonik.com

info@rheonik.com

Appendix B Technical Information

B.1 Technical Data

General Data	
Housing:	Wall Mount for harsh environment
Material:	SS316, connection box SS316 or aluminum
Enclosure Rating:	IP66 / NEMA 7X; IP67 optionally
Ambient Temperature:	-20°C to +60°C (-4°F to +140°F); -40 to +60°C optionally
Humidity:	10 to 90% relative humidity, non-condensing
Altitude:	up to 3000m, higher maximum altitude upon request
Dimensions:	See drawing chapter B.2
Weight:	8kg / 1.2lb
Display:	High contrast backlit LCD. Screen changes color to indicate warning or error
Operation:	3 x front panel operator buttons for all menu navigation and settings
Power Supply:	AC: 100-240 VAC (48 to 62 Hz), 6W DC: 12-24 VDC +/- 10%, 6W
Sensor Connection:	Integral sensor cable or terminal box with cage clamp terminals
Power Supply and I/O Connections	Screw type terminals in a connection box (construction types E*) Internal cage clamp terminals (construction types H*)
Cable entries sensor	1 or 2 cable glands 7 – 11mm (only construction types E5 and H3)
Cable entries power supply and I/O	2 cable glands 7 – 11mm (construction types E*) 2 threads NPT ½" (construction types H*)
Interfaces:	Modbus RTU (RS485) (standard) HART over analog output (option), USB (upon request)
Analog Outputs	
Type:	4-20mA compliant to NAMUR NE-43
Signal type and quantity:	1 or 2, passive floating or active referenced to GND, depending on I/O configuration
Output value:	Programmable, uncertainty +/-0.1% of reading +/- 10µA

Digital Universal Outputs	
Output signal:	Pulse, Frequency, Status
Type:	24V push-pull, according to IEC60946
Maximum current:	20mA (high state), 100mA (low state)
Frequency range:	0 ... 10 kHz
Quantity:	Up to 2, depending on I/O configuration
Output value:	programmable
Digital Status Outputs	
Output signal:	Status
Type:	24V push-pull, according to IEC60946
Maximum current:	20mA (high state), 100mA (low state)
Quantity:	Up to 2, depending on I/O configuration
Output value:	programmable
Digital Inputs	
Type:	24V, according to IEC60946
Input Level:	>13V for high state, < 6V for low state
Input Current:	1mA
Quantity:	1
Input value:	programmable
Analog Input	
Type:	4-20mA active compliant to NAMUR NE-43 For 2-wire passive sensor
Quantity:	Up to 1, depending on I/O configuration
Input value:	Pressure, uncertainty +/-0.1% of reading +/- 10µA

B.2 Mechanical Drawings

- Type E1, E2

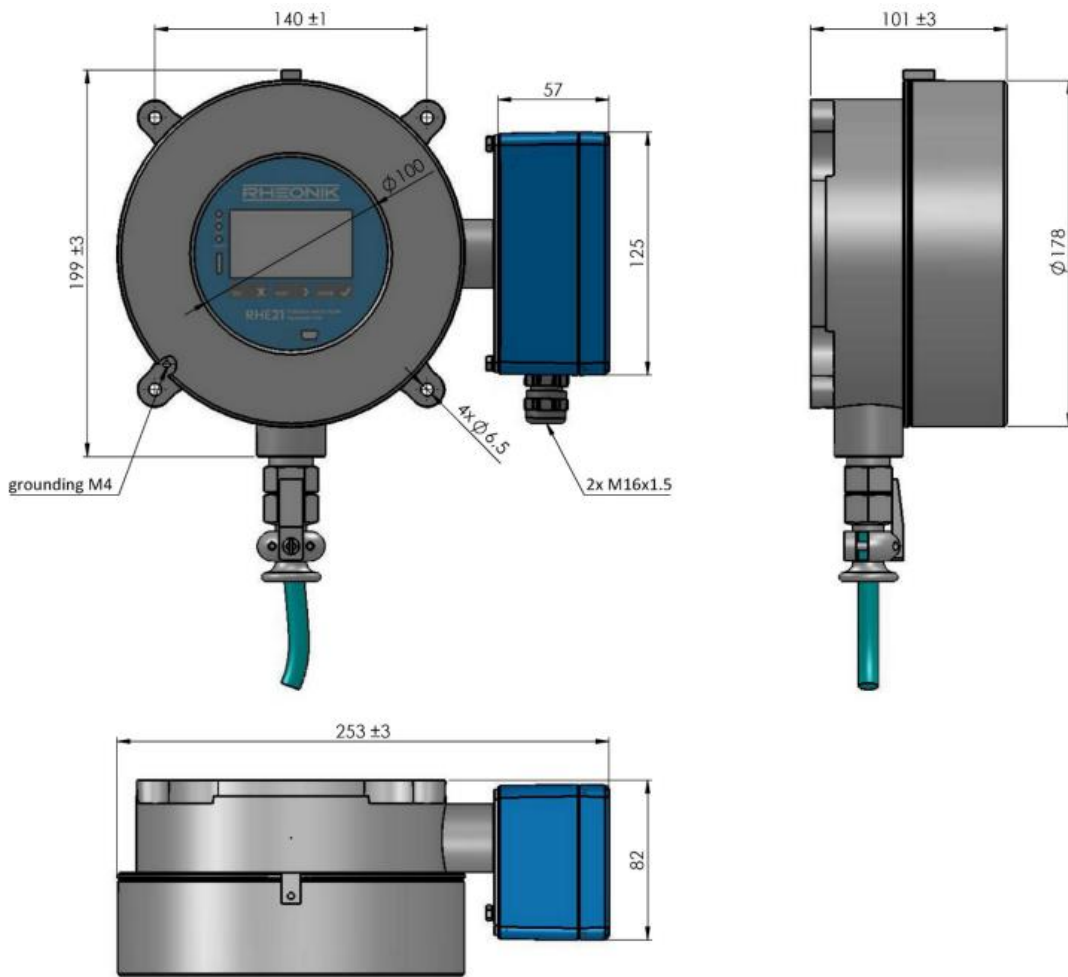

RHE21-E1,E2 Transmitter Dimensions (all dimensions in mm)

- Type E3, E4

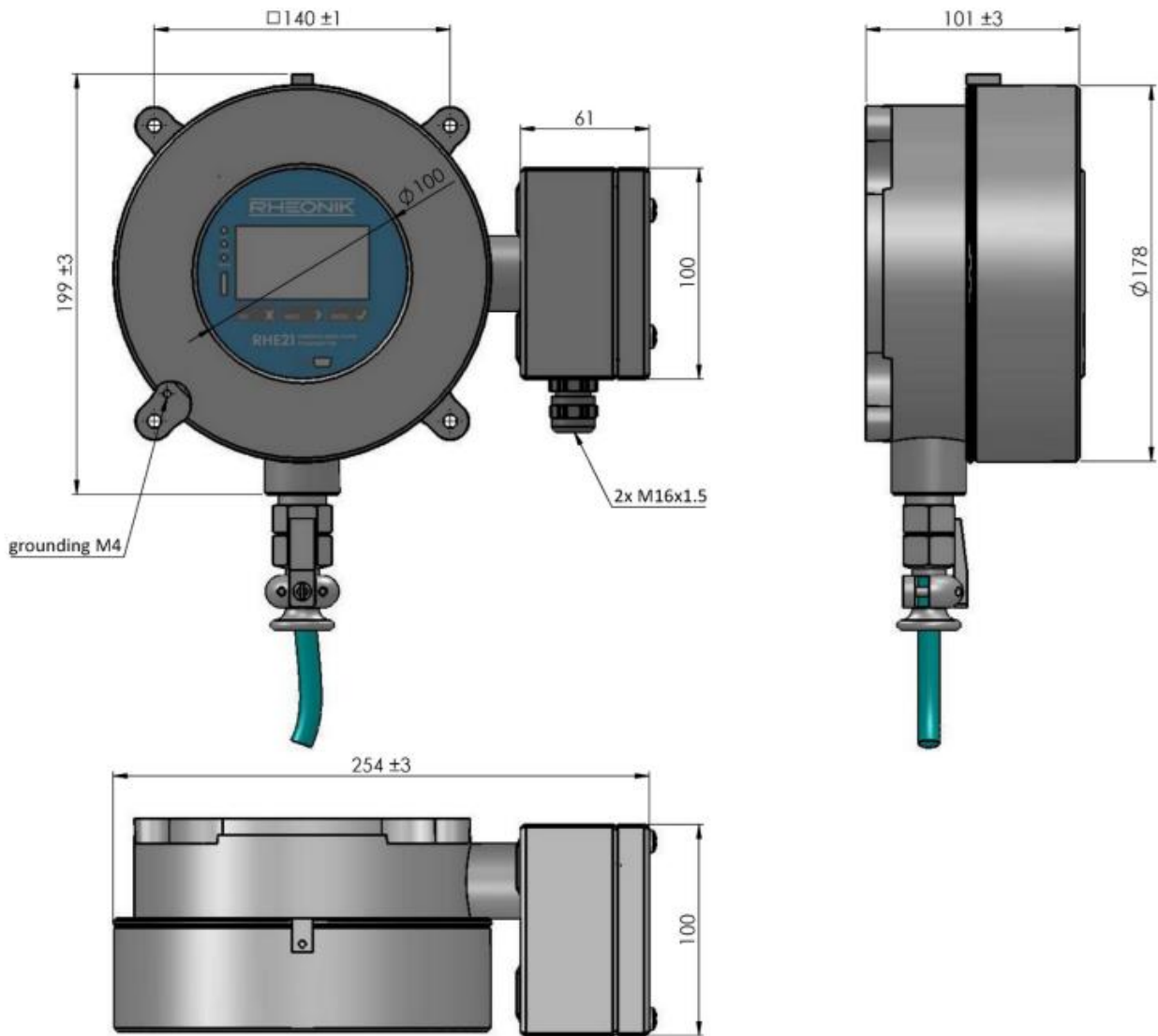

RHE21-E3,E4 Transmitter Dimensions (all dimensions in mm)

- Type E5

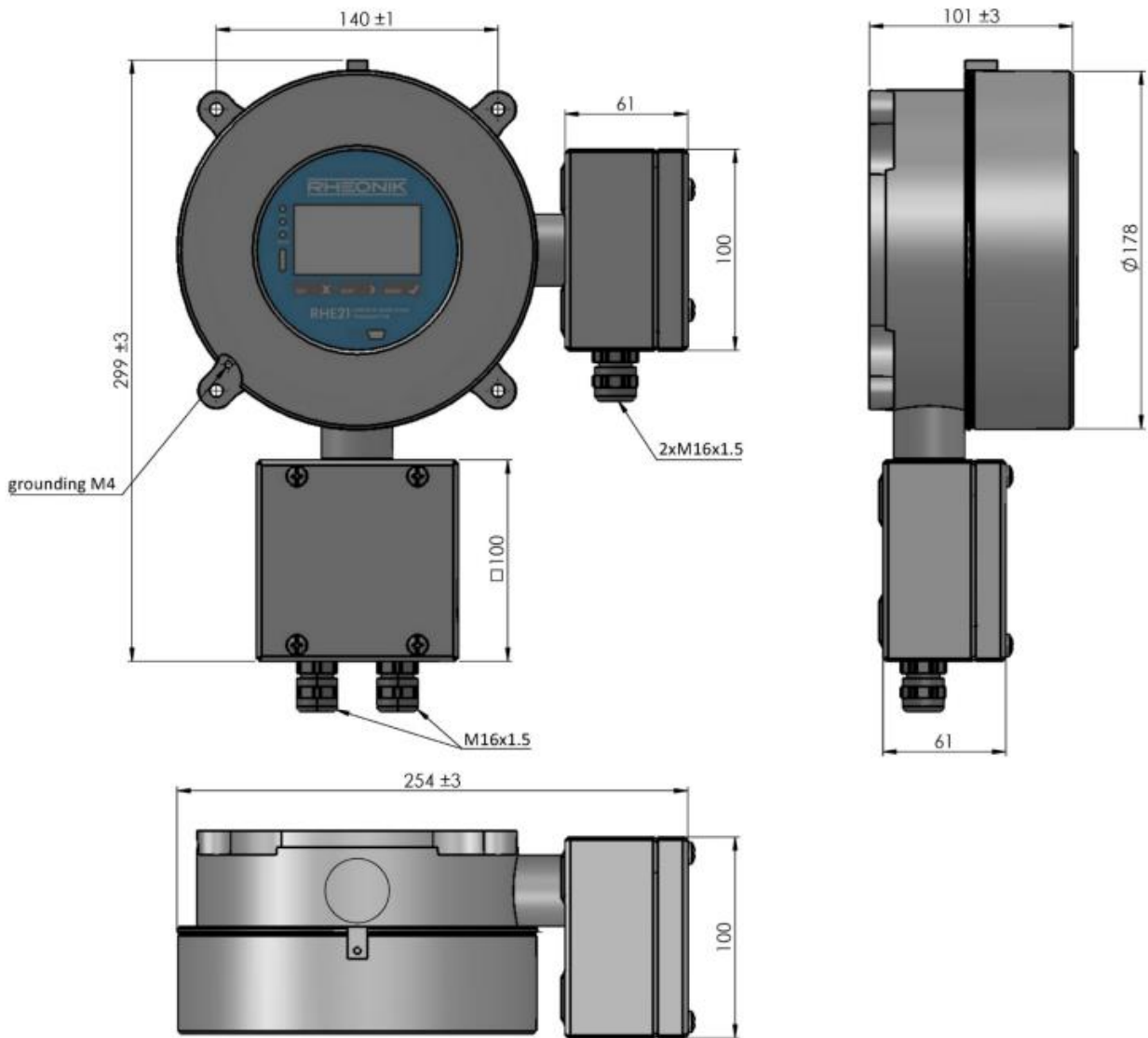

RHE21-E5 Transmitter Dimensions (all dimensions in mm)

- Type EP

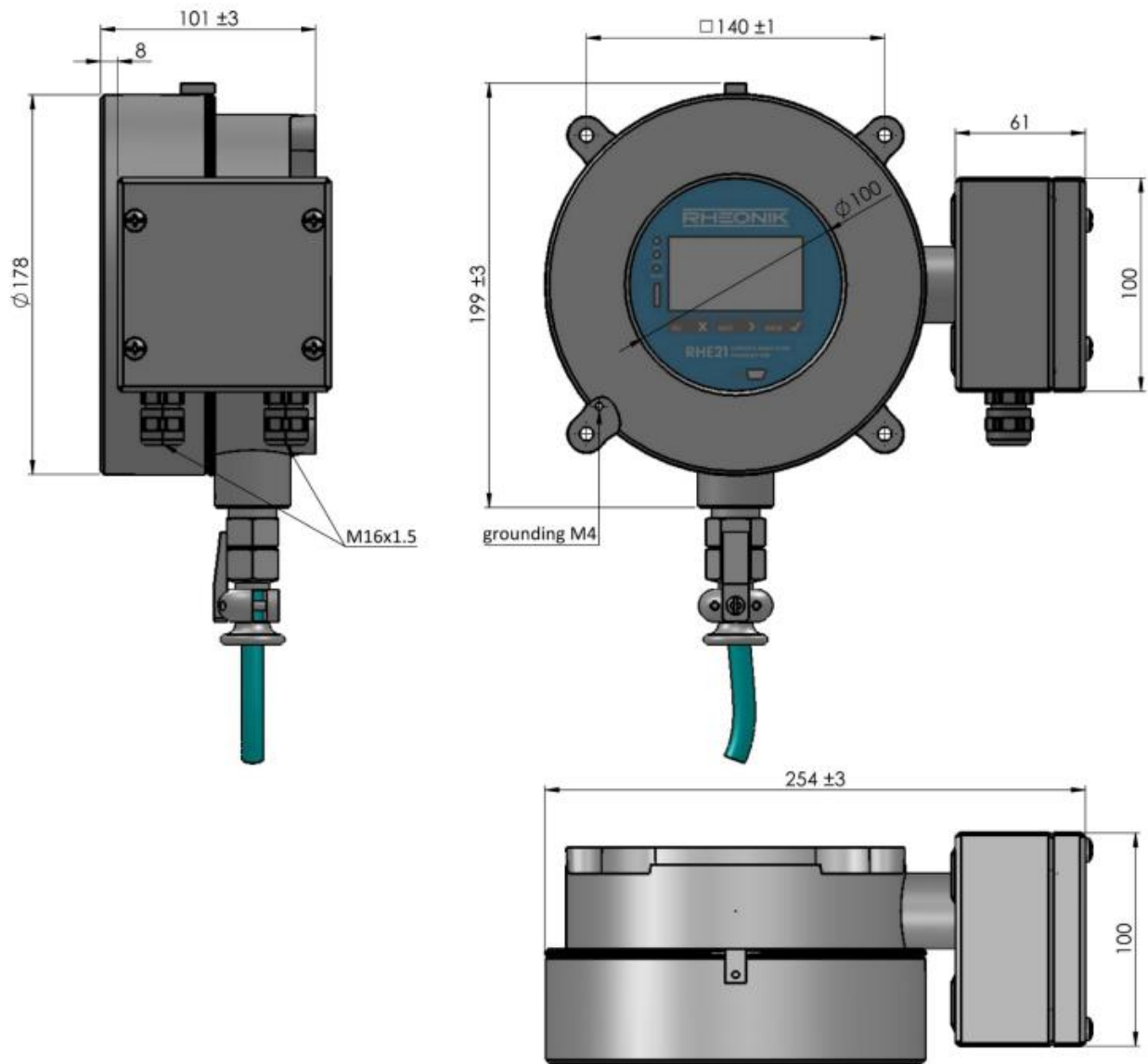

RHE21-EP Transmitter Dimensions (all dimensions in mm), type EP for panel mount: 8 mm recessed I/O terminal box to fit RHE21 display front into panel window

- Type H1, H2

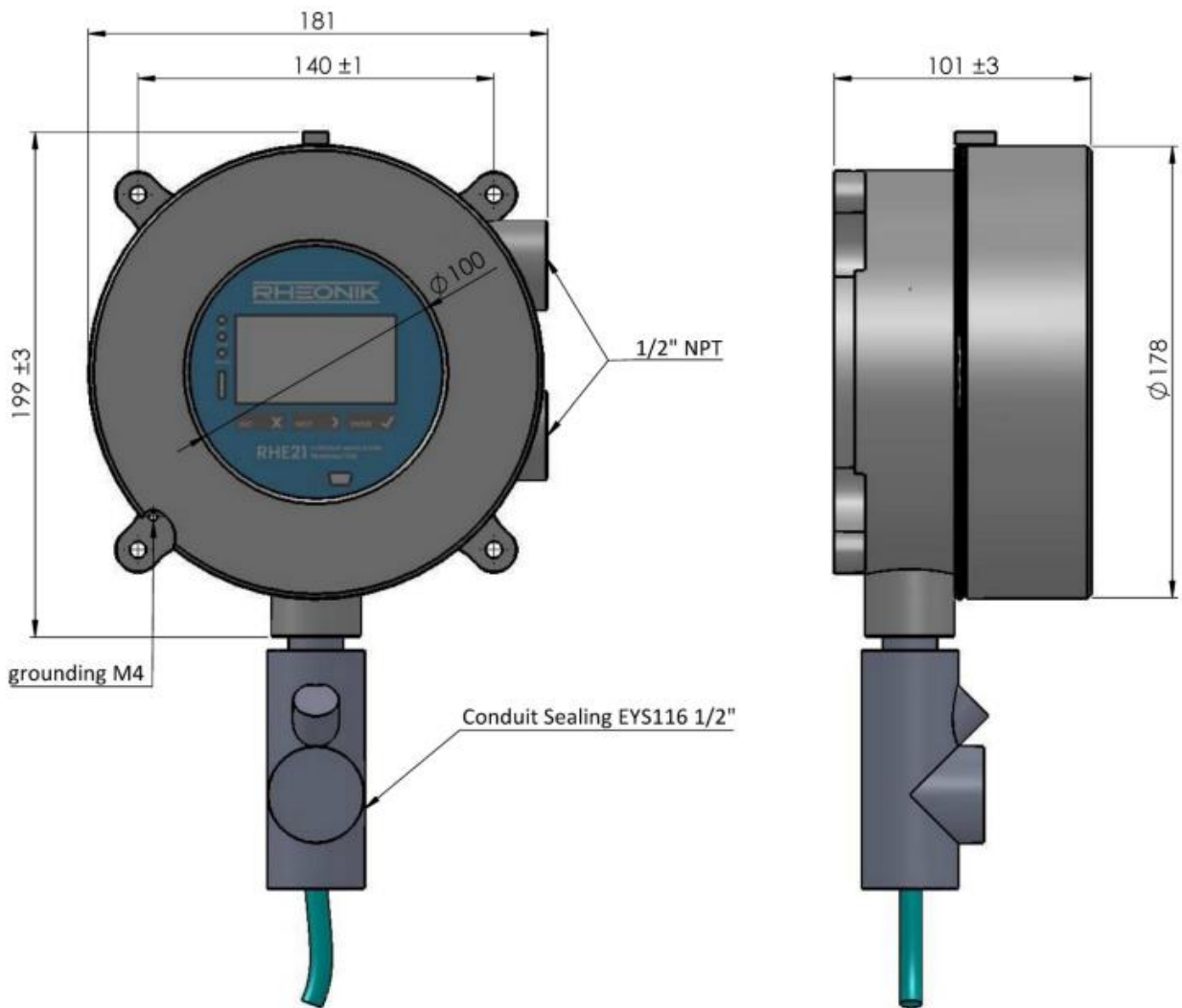

RHE21-H1,H2 Transmitter Dimensions (all dimensions in mm), figure shows CSA version ATEX/IECEx version has the same sensor connection part as type E1, E2, E3, E4

- Type H3

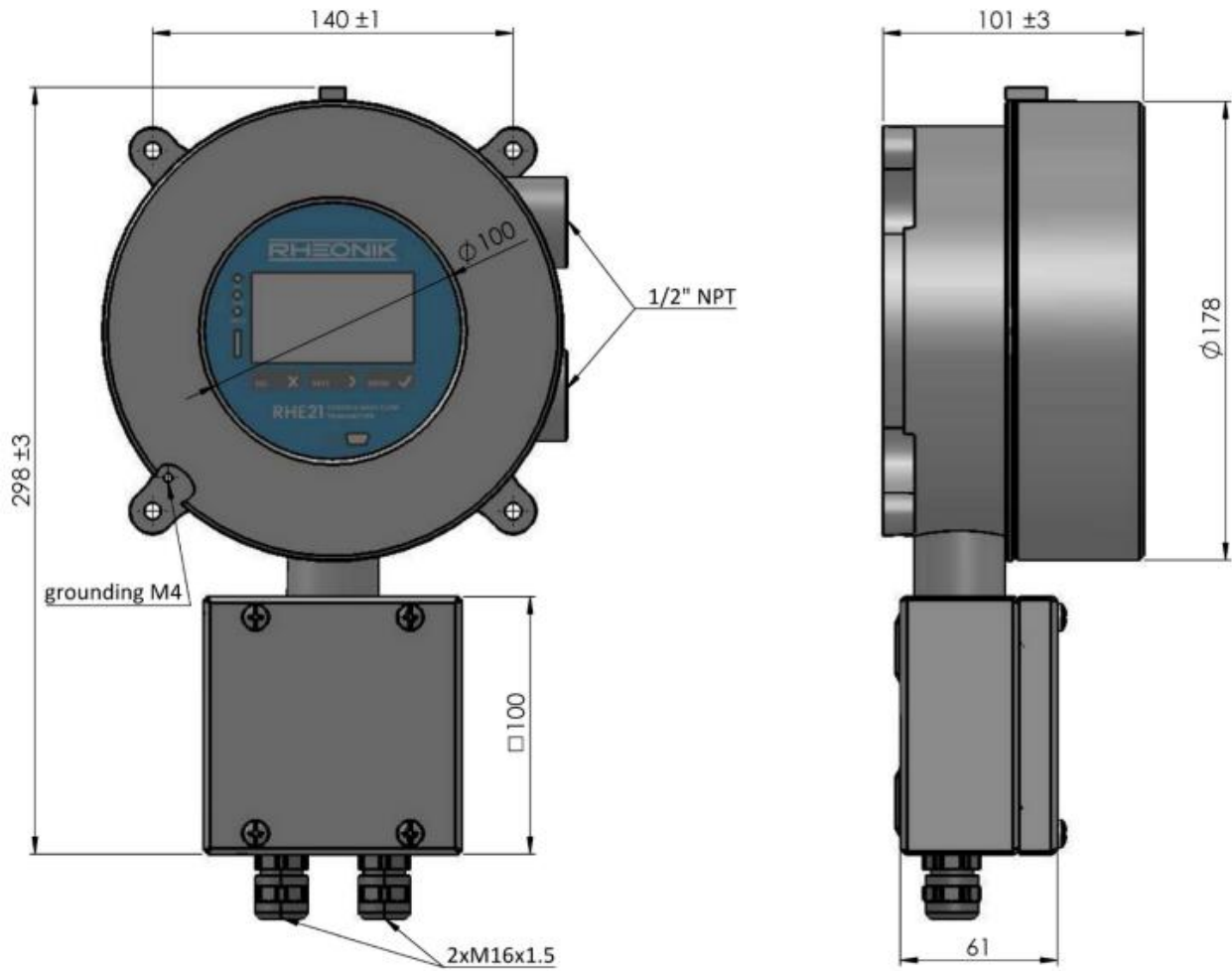

RHE21-H3 Transmitter Dimensions (all dimensions in mm), bottom sensor connection box with 1 x M16 gland standard, 2 x M16 glands only with analog input option

B.3 Mounting Drawing

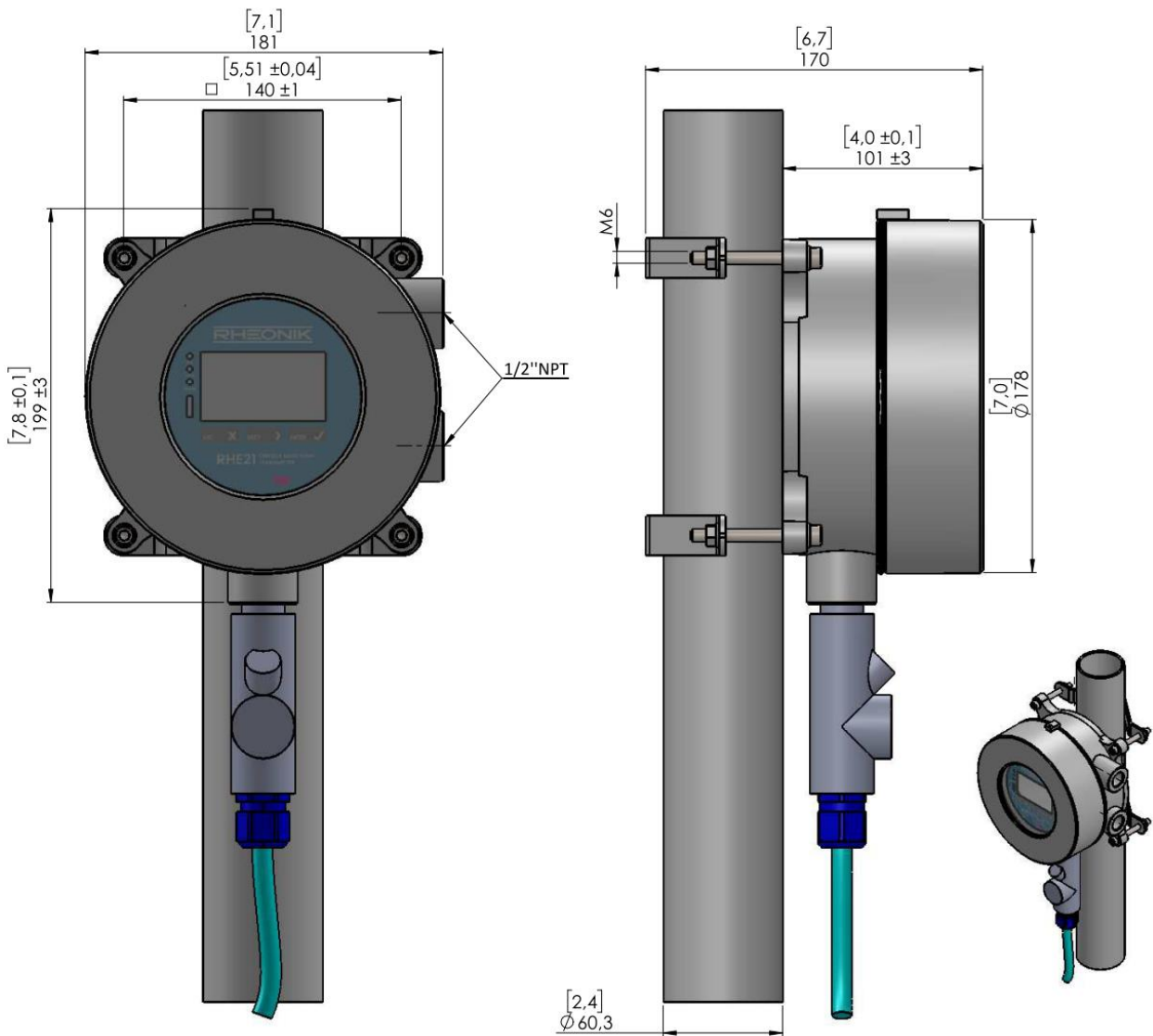

RHE21 pipe bracket mounting with accessory ARHE21-H (all dimensions in mm [inches])

The mounting brackets are designed for a 2" pipe (60.3mm / 2.4" outer diameter).
The screws must be tightened with a torque of 5 ± 1 Nm.



About Rheonik

Rheonik has but one single purpose: to design and manufacture the very best Coriolis meters available.

Our research and engineering resources are dedicated to finding new and better ways to provide cost effective accurate mass flow solutions that provide value to our customers. Our manufacturing group care for each and every meter we produce from raw materials all the way to shipping, and our service and support group are available to help you specify, integrate, start-up and maintain every Rheonik meter you have in service. Whether you own just one meter or have hundreds, you will never be just another customer to us. You are our valued business partner.

Need a specific configuration for your plant? Don't compromise with a "standard" product from elsewhere that will add extra cost to your installation. If we can't configure it from our extensive and versatile product range, our exclusive **AnyPipeFit Commitment** can have your flow sensor customized with any size/type of process connection and face to face dimension you need.

No matter what control system you use as the backbone in your enterprise, with our **AnyInterface Commitment**, you can be sure that connection and communication will not be a problem. Alongside a wide variety of discrete analog and digital signal connections, we can also provide just about any network/bus interface available (for example: HART, ProfibusDP, ProfiNet, EtherCAT, PowerLink, EtherNet/IP, CAN,) with our RHE 40 Series family of transmitters. Rheonik RHE 40 Series transmitters can connect to your system – no headache and no conversion needed.

Rheonik Messtechnik GmbH
Rudolf-Diesel-Straße 5
D-85235 Odelzhausen
Germany

Tel + 49 (0)8134 9341-0
info@rheonik.com



Addendum to:

RHE21 User Manual – Doc. No. 8.2.1.04 Version 1.35

RHE28 User Manual – Doc. No. 8.2.1.07 Version 1.37

RHE49 User Manual – Doc. No. 8.2.1.36 Version 1.10

Additional information to chapter 3 for RHE21:

3.3 Cable glands

Note for devices in hazardous areas:

The pressure screw must be tightened so that the sealing insert is flush with its upper edge.

Do not exceed the maximum tightening torques (see Table 1).

Lower torques are possible, however.

CAUTION: It is essential to avoid excessive swelling of the sealing insert!

Cable gland (Size)	Maximum tightening torques pressure
Pflitsch bg216**HTex (M16)	8 Nm

Table 1: Maximum tightening torques for the cable glands used by Rheonik. ** is used as a placeholder for the material.

Additional information to chapter 3 for RHE28:

3.3 Cable glands

Note for devices in hazardous areas:

The pressure screw must be tightened so that the sealing insert is flush with its upper edge.

Do not exceed the maximum tightening torques (see Table 2).

Lower torques are possible, however.

CAUTION: It is essential to avoid excessive swelling of the sealing insert!

Cable gland (Size)	Maximum tightening torques pressure
Pflitsch bg216**HTex (M16)	8 Nm

Table 2: Maximum tightening torques for the cable glands used by Rheonik. ** is used as a placeholder for the material.

Additional information to chapter 6 for RHE49:

6.3 Cable glands

Note for devices in hazardous areas:

The pressure screw must be tightened so that the sealing insert is flush with its upper edge.

Do not exceed the maximum tightening torques (see Table 3).

Lower torques are possible, however.

CAUTION: It is essential to avoid excessive swelling of the sealing insert!

Cable gland (Size)	Maximum tightening torques pressure
Pflitsch bg220**HTex (M20)	10 Nm
Pflitsch bg216**HTex (M16)	8 Nm

Table 3: Maximum tightening torques for the cable glands used by Rheonik. ** is used as a placeholder for the material.