



RHE 45 User Manual



Rheonik Messtechnik GmbH
Rudolf-Diesel-Straße 5
D-85235 Odelzhausen
Germany

Tel. + 49 (0)8134 9341-0
info@rheonik.com

LEARN
MORE



Document No.: 8.2.1.21
Version 1.04
December 2022

RHE 45

Transmitter

User Manual

RHEONIK.

Table of Contents

1	General Information	7
1.1	Important Safety Instructions for operating Coriolis Flowmeters	7
1.2	Manufacturer's Liability	7
1.3	Additional Resources	7
2	Quick Start	8
3	Installation	8
3.1	Mechanical Installation	8
3.2	Electrical Installation	9
3.2.1	Connectors	9
3.2.1.1	12-pin M12 Connector	9
3.2.1.2	8-pin M12 Connector	10
3.2.2	Power Supply and Grounding	10
3.2.2.1	Grounding and shielding	10
3.2.2.2	Power Supply	11
3.2.3	Control Inputs and Outputs	11
3.2.3.1	Digital Outputs	11
3.2.3.2	Analog Outputs	12
3.2.3.3	Digital Inputs	13
4	Operation and Configuration	14
4.1	Operating elements	14
4.1.1	External	14
4.1.2	Internal operating Elements	14
4.1.3	Zero Offset Calibration w/o interface	15
4.2	Operation and Configuration via Display	15
4.2.1	Function of the Pushbuttons	16
4.2.2	Passcodes and Menu Selection	17
4.2.3	Zero Offset Calibration	17
4.2.4	Change of Positive Flow Direction	18
4.2.5	Input/Output Configuration	19
4.2.5.1	Analog Output Configuration	19
4.2.5.2	Digital Output Configuration	20
4.2.5.3	Digital Input Configuration	22
4.3	Operation and Configuration via USB or RS485	23
4.3.1	Zero Offset Calibration	23

4.3.2	<i>Input/Output Configuration</i>	23
4.3.3	<i>I/O test</i>	24
4.3.4	<i>Internal System Time</i>	24
5	<i>Remote Operation</i>	25
5.1	<i>USB</i>	25
5.2	<i>RS485</i>	25
5.3	<i>Modbus TCP (I/O options EA and EB)</i>	26
5.4	<i>EtherNet/IP, ProfiNet and EtherCAT (I/O options EN, EP and EC)</i>	26
5.4.1	<i>ProfiNet Specific Information</i>	28
5.5	<i>Profibus DP (I/O option DP)</i>	29
6	<i>Service and Maintenance</i>	31
6.1	<i>Maintenance and Calibration</i>	31
6.2	<i>Supervision and Troubleshooting</i>	31
6.3	<i>Service</i>	31
6.4	<i>WEEE and RoHS</i>	31
7	<i>Ordering Code</i>	32
8	<i>Accessories</i>	33
Appendix A	<i>Technical Information</i>	34
A.1	<i>Technical Data</i>	34
A.2	<i>Mechanical Drawing</i>	36
Appendix B	<i>CE Certificate</i>	37

1 General Information

1.1 Important Safety Instructions for operating Coriolis Flowmeters



The RHE45 transmitter model is integrated in the RHM flow sensor. Maximum temperature limits for each RHM flow sensor are stated on the permanently attached serial number plate and must not be exceeded.

The closed transmitter box provides a protection class of at least IP66.

The use of a properly grounded supply is highly recommended.

The use of shielded cables for all I/O signals is recommended to prevent interference from high level EMI.

For safety instructions regarding RHM Coriolis Flow Sensors, please refer to the RHM installation and startup guide manual.

These measuring instruments are not designed for, and should not be installed in, life-preserving systems used in the medical, motor vehicle, aircraft, water craft or mining industries.

All national regulations and standards regarding electrical installation must be observed!

1.2 Manufacturer's Liability



Rheonik assumes no liability for loss and/or consequential damages stemming from the use of this product utilized in life-preserving systems in the medical, motor vehicle, aircraft, water craft or mining industries.

Rheonik accepts no liability for loss or damage resulting from the improper use of any of its products.

Rheonik assumes no liability for the loss of production and/or consequential damage from the use of this product unless such liability has been expressly and contractually agreed.

Rheonik provides a standard one year from shipment warranty on all products for workmanship and materials. Performance of this warranty will be at the Rheonik manufacturing facility.

Rheonik assumes no liability for determining the suitability of its products in any specific application. This is the sole responsibility of the end user.

1.3 Additional Resources

Since this document mainly describes the installation and commissioning of the RHE45 transmitter it does not contain all information related to the configuration of the transmitter and its features. These items are described extensively in the documents listed in Table 1. Manuals and further resources are available for download from the Rheonik website:

www.rheonik.com



Table 1: Additional Documentation

Title	Description	Document Number
RHE4X Desktop Reference	Extensive description of the configuration options of the RHE4X transmitter series.	8.2.1.14
Addendum RHE4X Desktop Reference Data Logging	Description of the data logging feature present in the RHE4X transmitter series.	8.2.1.15
Addendum RHE4X Desktop Reference Statistics	Description of the statistic feature present in the RHE4X transmitter series.	8.2.1.28
RHEComPro Suite User Manual	Installation and use of the RHEComPro Suite for PC for the operation and configuration of the RHE transmitters.	8.2.1.18

2 Quick Start

Carry out the following steps to prepare the flow meter for operation:

- 1) If not already done, install the RHM sensor in line (refer to the RHM Coriolis Sensor Installation Guide for additional information on mechanical installation).
- 2) Connect all signal input, output and communications interface wiring as required (section 3.2.3).
- 3) Connect power supply (section 3.2.2).

NOTE:

For safety, always connect the protective ground.

- 4) Switch on the power supply. The “READY” LED will light up (only visible when transmitter enclosure is opened).
- 5) Flush the RHM flow sensor with process fluid and ensure that it is free of air bubbles (in case of a liquid process fluid) or liquid droplets (in case of a gaseous process fluid).
- 6) Wait until the RHM temperature has stabilized and then carry out a zero point calibration (section 4.3):
 - Ensure a zero flow condition is present in the flow sensor by closing isolation valves
 - Initiate zeroing of the sensor and wait for the zeroing procedure to complete
 - Open isolation valves to allow flow through the sensor

The device is ready for operation.

3 Installation

3.1 Mechanical Installation

The RHE45 is connected to the RHM ex works and cannot be removed.

For mounting the RHM refer to the corresponding manual delivered with the RHM.



When hot fluids are to be measured the housing of the RHE45 must not be thermally isolated from the ambient for avoiding overheating the electronics.

When planning the mechanical installation please leave at least 12.5 cm/5 inch space for the M12 plugs and the attached cables at the side where the M12 sockets are located.

Technical data and mechanical drawings can be found in Appendix A.

3.2 Electrical Installation



Caution, the surface of the RHE45 may be hot if a hot fluid is running through the RHM sensor.

Any cable used for connecting to the RHE45 must be specified for 80°C or higher.

The use of shielded cable is strongly recommended.

3.2.1 Connectors

The RHE45 has one 12-pin M12 connector, “A” coded, for power supply and standard interfaces and one 8-pin M12 connector, “A” coded for high-speed interfaces of Ethernet 100base TX type.

With the I/O configurations B1, S1, S2, P1, and P2 the 8-pin socket is internally not connected.

If the 8-pin M12 connector is not used, it must be closed with the protection cap delivered with the RHE45 for maintaining the ingress protection.

As accessories Rheonik offers readily configured cables. For available accessories see chapter 8.

3.2.1.1 12-pin M12 Connector

The 12-pin M12 connector of the RHE45 provides power supply, RS485 interface, digital outputs, digital input, and the analog 4-20mA interfaces.



Caution: Before connecting the 12-pin M12 socket please check that the power supply is correctly connected to the pins 1 and 3 of the 12-pin M12 plug to prevent damage.

The following figures show the pin numbering of the 12-pin M12 socket in the RHE4X transmitter and a respective plug.

Top
View
Socket

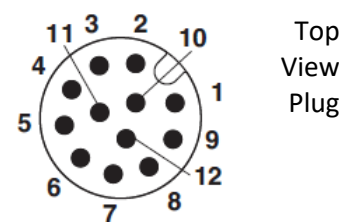
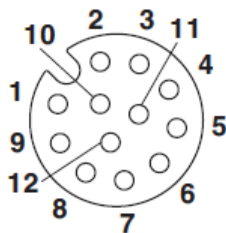

Top
View
Plug

Figure 1: Pin Numbering of the RHE45 12-pin M12 Socket

Figure 2: Pin Numbering of an 12-pin M12 Plug

Table 2: Pin Configuration of the 12-pin M12 Socket

Pin #	Signal	I/O Option	Remark
1	+24V	all	Positive supply terminal
2	AO1-	S1, S2, P1, or P2	Negative terminal for analog output 1
3	0V/GND	all	Ground for power supply
4	RS485-	all	Negative signal of the two-wire RS485 interface
5	DO1	all	Digital output 1 (called channel 0/A in the Modbus documentation)
6	RS485+	all	Positive signal of the two-wire RS485 interface
7	DI1	all	Digital input 1
8	DO2	all	Digital output 2 (called channel 1/B in the Modbus documentation)
9	AO1+	S1, S2, P1, or P2	Positive terminal for analog output 1
10	I/O GND	all	Ground for digital in- and outputs
11	AO2+	S2, or P2	Positive terminal for analog output 2
12	AO2-	S2 or P2	Negative terminal for analog output 2
Shield	Ground / PE	all	

3.2.1.2 8-pin M12 Connector

The 8 pin M12 connector is only connected internally, if one of the following options (see ordering code section 7) is installed:

EA, EB	Modbus TCP
EN	EtherNet/IP
EP	ProfiNet
DP	Profibus DP
EC	EtherCAT

The drawing shows the pin numbering of a 8 pin M12 connector. The function of the pins for the different options is described in chapter 5.

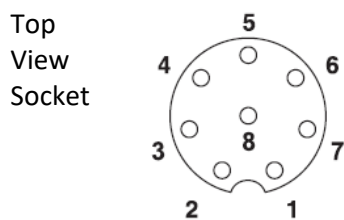

Figure 3: Pin Numbering of the RHE45 8-pin M12 Socket

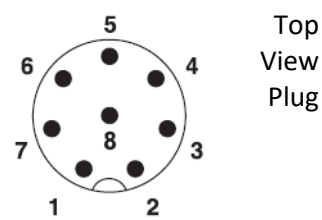



Figure 4: Pin Numbering of an 8-pin M12 Plug

3.2.2 Power Supply and Grounding

For connections longer than 0.5m shielded cables should be used. For connections longer than 3m, additional ferrite filter beads close to the RHE are recommended for avoiding RF EMI.

The power supply input is protected by a fuse. As a protection against fire in case of a short in the cable, the supply side of the cable should be protected by a fuse (see figure 5, S11) with a rating not higher than the current carrying capacity of the cable.

The ground signal of the RHE45 (Terminal 3 and 10 of the 12 pin M12 connector) is connected to PE and housing via a 10kΩ resistor.

 The cables used for power supply and grounding must comply with the national requirements. If required, certified cables must be used. The minimum cross section is 0.35mm² (AWG 22).

The RHE45 does not contain a mains switch. A switch or circuit breaker close to the RHE45 must be included in the supply line. The switch must be marked correspondingly.

3.2.2.1 Grounding and shielding

An RHM with an RHE45 transmitter must be grounded. Refer to the manual of the RHM for the position of the ground terminal.

The cross sectional area of the grounding wire must be equal to or larger than the conductors used for any supply or I/O connection.

Note: National and Local electrical code requirements may contain additional grounding requirements. Please ensure that all grounding is carried out to these [legal] requirements.

For connections longer than 0.5m shielded cables should be used. For best EMC performance the shield should be connected on both ends of the cable. If the shield cannot be connected on both ends due to potential differences between PE on both ends, one end might be connected to PE via a 1nF capacitor on one end.

3.2.2.2 Power Supply

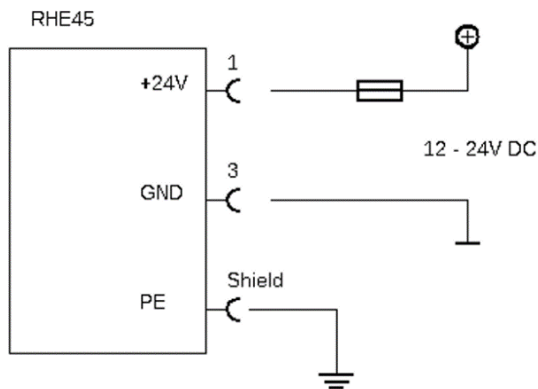

Figure 5: DC Power Supply

The RHE45 requires a regulated DC supply voltage of 12V or 24V. It will operate with a power supply in the range 10V to 28V.

Connect the positive supply to terminal 1 and 0V to terminal 3 of the 12 pin M12 connector.

Terminal 3 (0V) and housing (PE) are connected via a 10k Ω resistor. The resistor can withstand a potential difference of up to 30V between 0V and PE, but voltage differences above 5V should be avoided. For best EMC performance connect the supply ground to PE close to the RHE45.

3.2.3 Control Inputs and Outputs

In general, shielded cables should be used for cable connections longer than 0.5m. For cable connections longer than 3m, it is recommended that ferrite filter beads are installed close to the RHE terminations to help avoid RF EMI.

3.2.3.1 Digital Outputs

The RHE45 has two universal digital outputs which can be used as frequency, pulse or control/status outputs.

Digital outputs are push-pull outputs compliant to IEC 60946. They can drive loads connected to ground and loads connected to +24V.

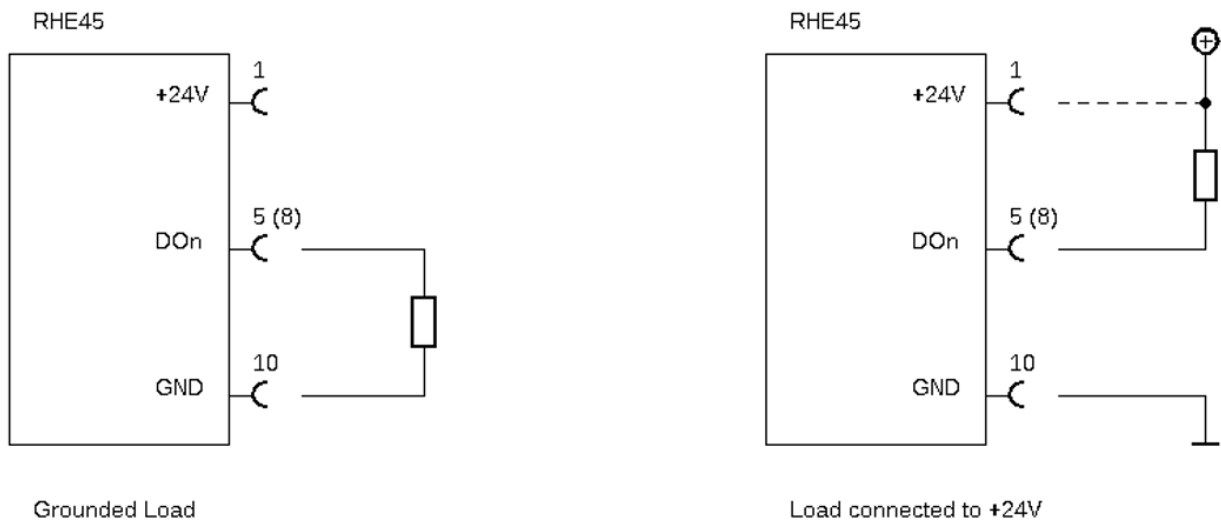

Figure 6: Digital Outputs

Connect the output of the RHE to the load. Connect the other side of the load to either GND or to the positive supply rail. With a grounded load, the output current should be limited to 20mA (480mW at 24V). With a load connected to the positive supply rail the output can drive up to 50mA (1.2W at 24V).

The output can drive relays directly as well. Relays should be connected between the output and the positive supply rail.

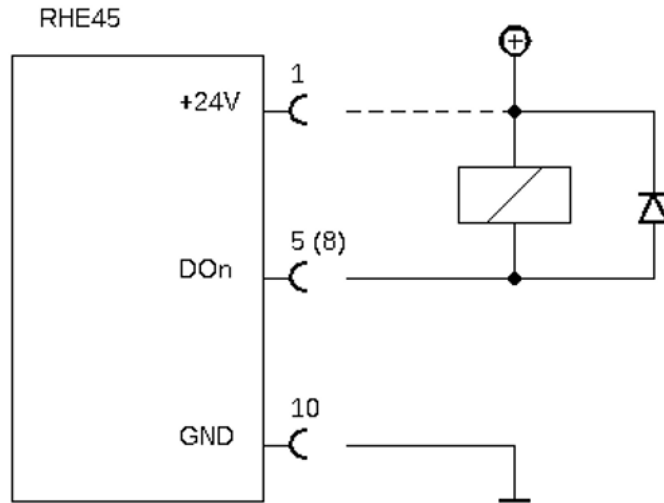

Figure 7: Digital Output with Relays

The maximum output current is internally limited to 50mA. If the output current exceeds this limit due to a too low load resistance, the output will be disabled automatically.

3.2.3.2 Analog Outputs

Depending on the I/O configuration ordered, the RHE45 has passive, active or no analog outputs.

The minimum current of the analog 4-20mA interfaces is limited to 3.2mA. Thus, fire state settings of 2.0mA or 0.0mA are silently corrected to 3.2mA by the RHE45 firmware.

Passive analog outputs (I/O option P1 or P2):

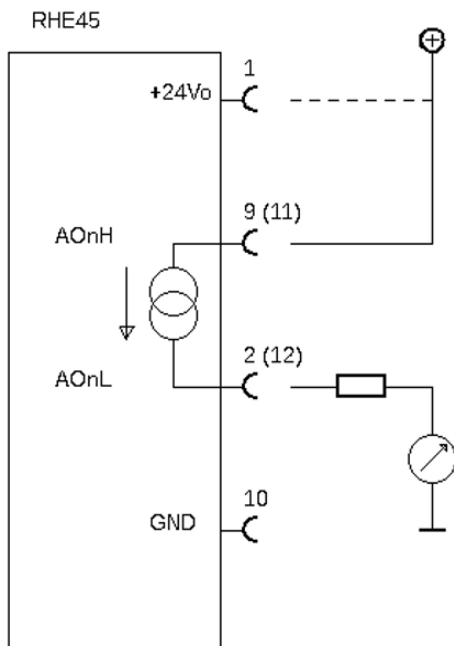

Connect terminal 9 (11 for output 2) to the positive terminal of a 24V supply (12V would be possible as well) and terminal 2 (12 for output 2) to the load. The negative terminal of the load must be connected to the GND terminal of the supply.

A protective resistor can be connected in series with the transmitter output and the load. Please note, with a 24Vdc supply, the maximum total load resistance is 600 Ω .

Figure 8: Passive Analog Outputs

Active analog outputs (I/O option S1 or S2):

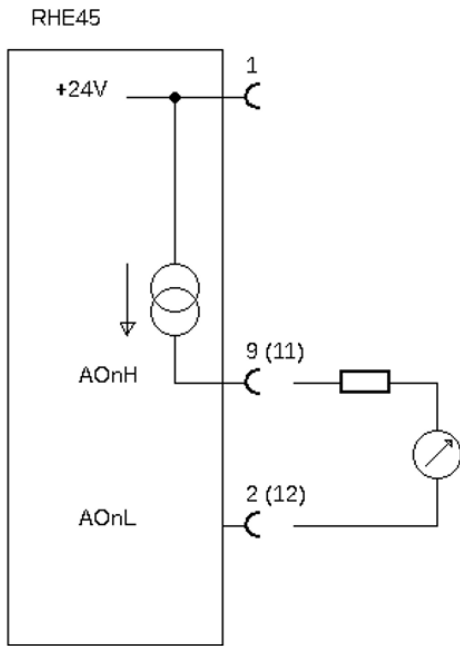

Connect load between terminal 9 (11 for output 2) and GND.

A protective resistor can be connected in series with the transmitter output and the load. Please note, with a 24Vdc supply, the maximum total load resistance is 600 Ω .

Figure 9: Active Analog Outputs

3.2.3.3 Digital Inputs

RHE45 transmitters have one or two IEC60946 compliant digital inputs.

Digital inputs have an input resistance of 24 k Ω and when operated, will draw approx. 1mA when connected to a 24Vdc supply.

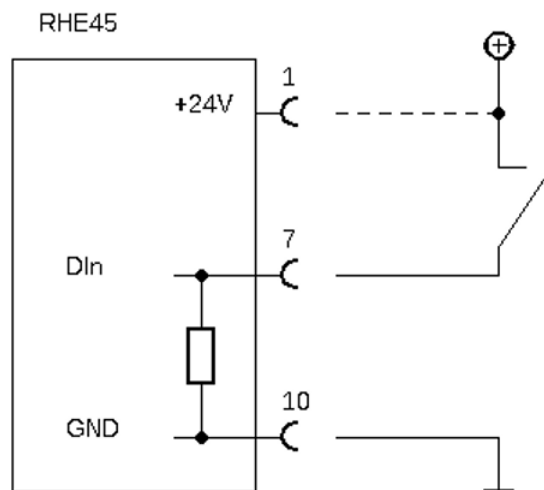

Figure 10: Digital Inputs

Digital inputs can be operated with an active DC signal instead of a switch. The maximum input voltage must not exceed 30V DC. The required input voltage for a low-high transit is typically 11V, maximum 12.5V, corresponding to an input current of about 0.5mA.

The digital input 2 is available with I/O option EA and EB only. The input is located on the 8 pin M12 connector, pin 2 (DI2) and pin 3 (I/O GND).

4 Operation and Configuration

4.1 Operating elements

4.1.1 External

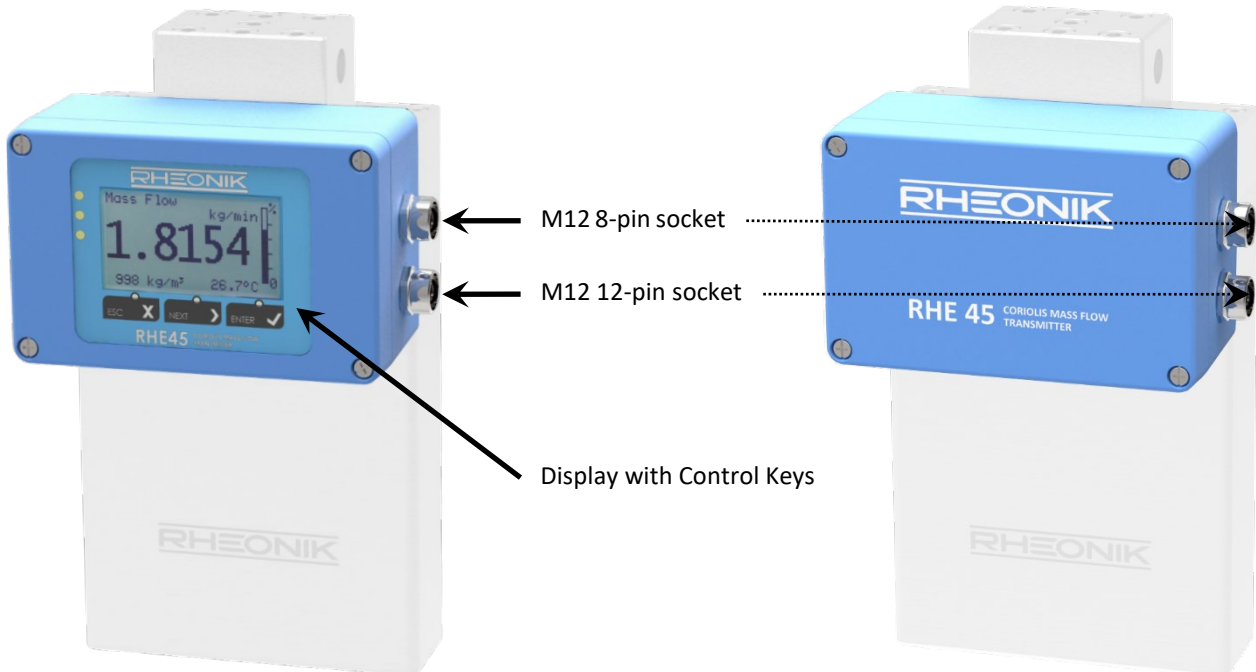

Figure 11: RHE45 Enclosure in Standard Orientation

If the 8-pin M12 connector is not used, it must be closed with the protection cap delivered with the RHE45 for maintaining the ingress protection.

4.1.2 Internal operating Elements

When the cover of the RHE45 enclosure is removed a part of the electronics becomes accessible which contains some user configurable elements, e.g.:

1. Mini USB socket (see chapter 5.1)
2. Status LEDs, green (ON), yellow (Hard Lock switch active), red (ERROR)
3. Hard Lock switch (option)
4. RS485 termination switch
5. Push button "ZERO"
6. Power supply fuse
7. Display with control keys (optionally)

Figure depicts the RHE45 transmitter without display when the cover is open.



When opening the cover of the RHE45 enclosure make sure that no fluids enter the enclosure and observe basic EMC measures such as connecting yourself to the earth potential of the enclosure.

Figure also shows the switch positions for the activation or deactivation of the RS485 termination and the Hard Lock switches. The activation of the Hard Lock switch also will be shown by the yellow LED being lit. In this case no modification of setup parameters is possible.



Figure 12: RHE45 with Open Enclosure

4.1.3 Zero Offset Calibration w/o interface

After installation of the RHM with RHE45 a zero calibration is strongly recommended.

- Flush the RHM with the fluid to be measured and make sure that the RHM is 100% filled.
- Operate the RHE45 for at least 15 minutes for warming up.
- Open the top cover of the RHE by removing the 4 screws in the corners of the top cover.
- Stop the flow and make sure that there is no more flow. For best results a valve in front and behind the RHM would be recommended.
- Press the pushbutton “ZERO” with a tool (screwdriver, pencil) for about 2 seconds. The red and the green LED star flashing.
- When the flashing stops and the green LED lights constantly reclose the top cover.
- Reopen the valves.
- Make sure that the top cover gets properly closed for achieving the IP protection.



The RHE45 must not be opened in wet or dirty (dusty) ambient or when the housing of the RHE45 is wet.

4.2 Operation and Configuration via Display

Optionally, the RHE45 transmitter has a user operation interface consisting of a color LCD screen and three pushbuttons. The screen and pushbuttons are used to navigate through a hierarchical menu structure that logically and intuitively organizes the various features and functions available within the programming set supplied with the instrument. This chapter gives a short introduction into operation of the RHE45 through the front panel user interface. For more detailed information, please refer to the RHE4X Desktop Reference Manual.

4.2.1 Function of the Pushbuttons

RHE45 transmitters can be operated through three front panel pushbuttons. These are labeled “ESC” [X], “NEXT” [>], and “ENTER” [✓]. The function of these pushbuttons depends upon the currently displayed screen.

The following table details button function in specific situations.

Table 3: Functions of the Pushbuttons

Button	Situation	Function
ESC	Menu Navigation	Navigates to the menu one level up
	Number Input	Exits number input field and returns to the associated menu window without saving any changes
NEXT	Menu Navigation	Selects the next menu item
	During Number Input	Increments the number at the cursor position by one. Number increment is circular: a ‘9’ increments to ‘0’ for decimal numbers, ‘F’ increments to ‘0’ for hexadecimal numbers (used for service password)
	Number Sign Change	Changes ‘+’ to ‘-’ and vice versa. When entering a number with a sign character, the cursor will start at the first number character to the right of the sign character in the field. In order to reach the sign character, it is necessary to traverse all the way to the rightmost character and then start at the beginning of the input field again
	Decimal Point Position Change	Shifts the decimal point and cursor position one place to the right
	End of input line	The entire number will flash upon pressing ENTER at the rightmost character in an input field. Pressing NEXT when the field is flashing will return the cursor to the start of the input line
ENTER	Menu Navigation	Navigates to the menu one level down or enters an input screen
	During Number, Sign or Decimal Point entry/ change	Moves the cursor one character to the right in an input field. Note that when a number is entered that is not in the parameters’ acceptable range, the field will change to inverse colors (light on dark instead of dark on light). When a number is not within an acceptable range, pressing ENTER at the rightmost character in the field will return the cursor to the leftmost position in the field for re-editing.
	Number Input at the End	Pressing ENTER at the rightmost character in the field will cause the entire field to flash. Pressing ENTER again will commit the modified number and return display to the associated menu window
	Status Infos - Bit Status Displays	Increment the index of individual bits in the status words. Successively pressing ENTER in the Error Status, Soft Error Status, or Warnings items will allow display/read of each individual bit value and its status description

For example, and as depicted in Figure 13, when navigating the menu structure, press the ENTER pushbutton once to get from the main display screen to the top level menu selection. Press the NEXT button repeatedly to scroll through the entire menu. To enter any specific menu, press ENTER.

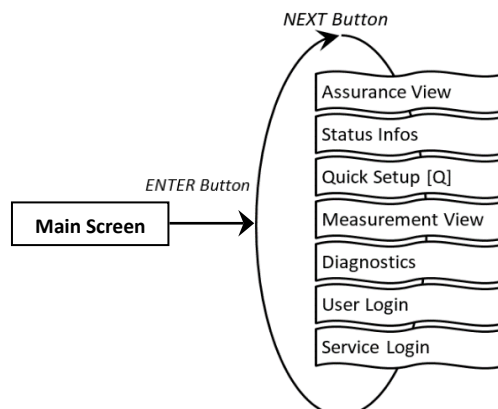

Figure 13: Example – RHE45 Top Level Menu Selection

4.2.2 Passcodes and Menu Selection

To configure and carry out certain functions in an RHE45 transmitter, it is necessary to enter a predetermined passcode. Passcodes protect configuration setup and prevent inadvertent changes to the flow meter operating condition. There are two different access levels with separate passcodes: “USER” and “SERVICE”. The USER level accesses those functions that relate to the operation of the flow meter on a day to day basis i.e. zeroing and totalizer reset. The SERVICE level allows access to configuration and setup functions such as I/O ranging and calibration.

When needed, the screen will prompt for a passcode. Passcodes are entered using the NEXT and ENTER buttons. Once entry is complete, the entire passcode will flash. Press ENTER again to enter the menu. If the passcode supplied is incorrect, the cursor will return to the leftmost character of the passcode for re-entry.

Factory default passcodes are shown in Table 4. The USER level passcode can be changed by accessing the “Service Login” menu.

Table 4: Default Passcodes

Access Level	Passcode
User	1111
Service	5678

4.2.3 Zero Offset Calibration

Before carrying out a zero offset calibration, make sure that there is a zero flow condition in the RHM sensor i.e. valves have been closed upstream and downstream of the RHM meter body.

Navigate to the “Zero Now” menu item as shown in Figure 14 to perform the zeroing procedure. It will be necessary to enter the user passcode (see section 2.2).

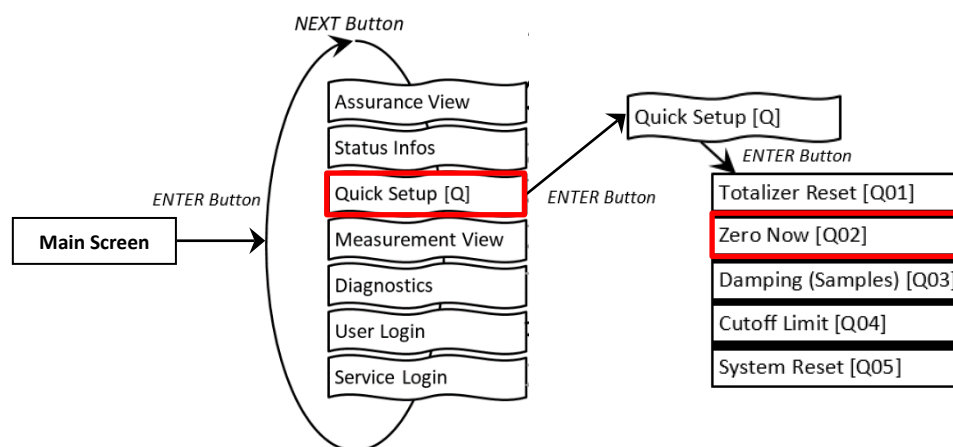

Figure 14: RHE45 Menu - Zero Offset Calibration

To perform the zeroing procedure, press NEXT at the Y/N confirmation screen to change the “N” to “Y”. Press ENTER to start the procedure or ESC to cancel. Once started, a countdown timer will begin. When it reaches 0, the zero offset calibration procedure is complete. Return back to the main screen by pressing the EXIT pushbutton twice.

4.2.4 Change of Positive Flow Direction

Rheonik mass flow meters are bi-directional and can operate with flow passing through them in any direction. In some cases after installation, the transmitter may read negatively because of orientation. In this case, the flow direction indication can be reversed within the transmitter. To change the positive flow direction, navigate to the “Phase Measurement” menu item under Service Login (Figure 15).

Change the value of the “PhsFlwDirConfig” parameter from “0” to “1” (or vice versa) to change the flow direction indication of the transmitter.

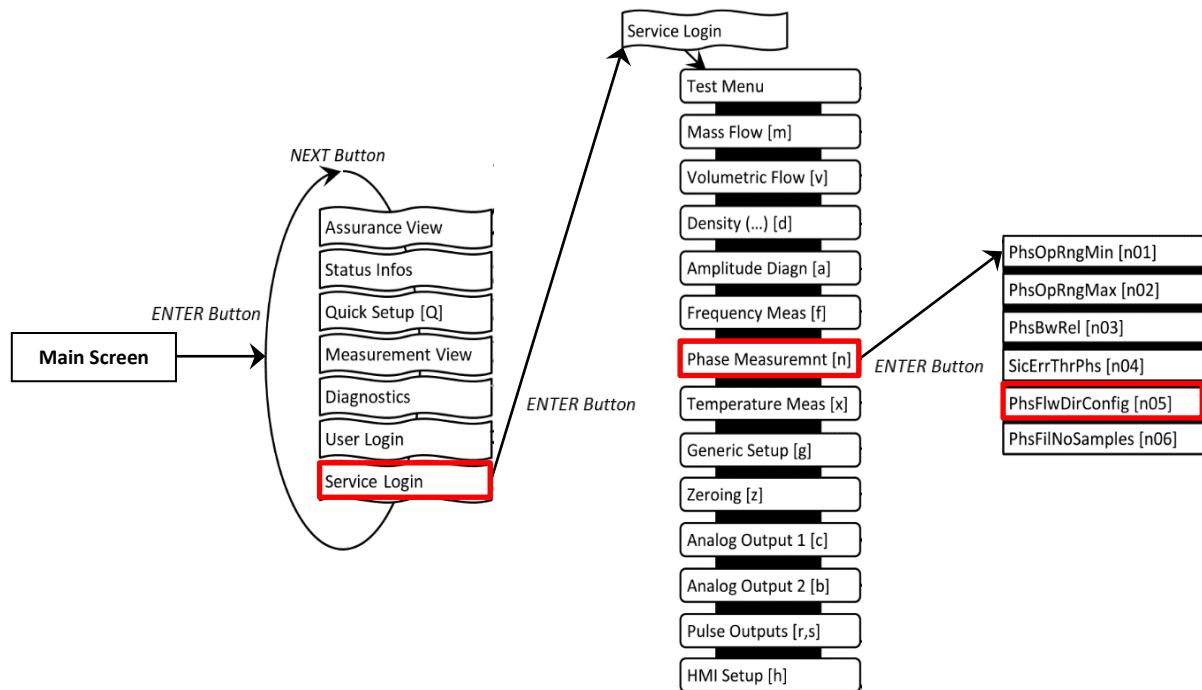

Figure 15: RHE45 Menu - Flow Direction Change

4.2.5 Input/Output Configuration

To configure the analog and digital outputs, navigate to the respective menu items under User Login (Figure 16).

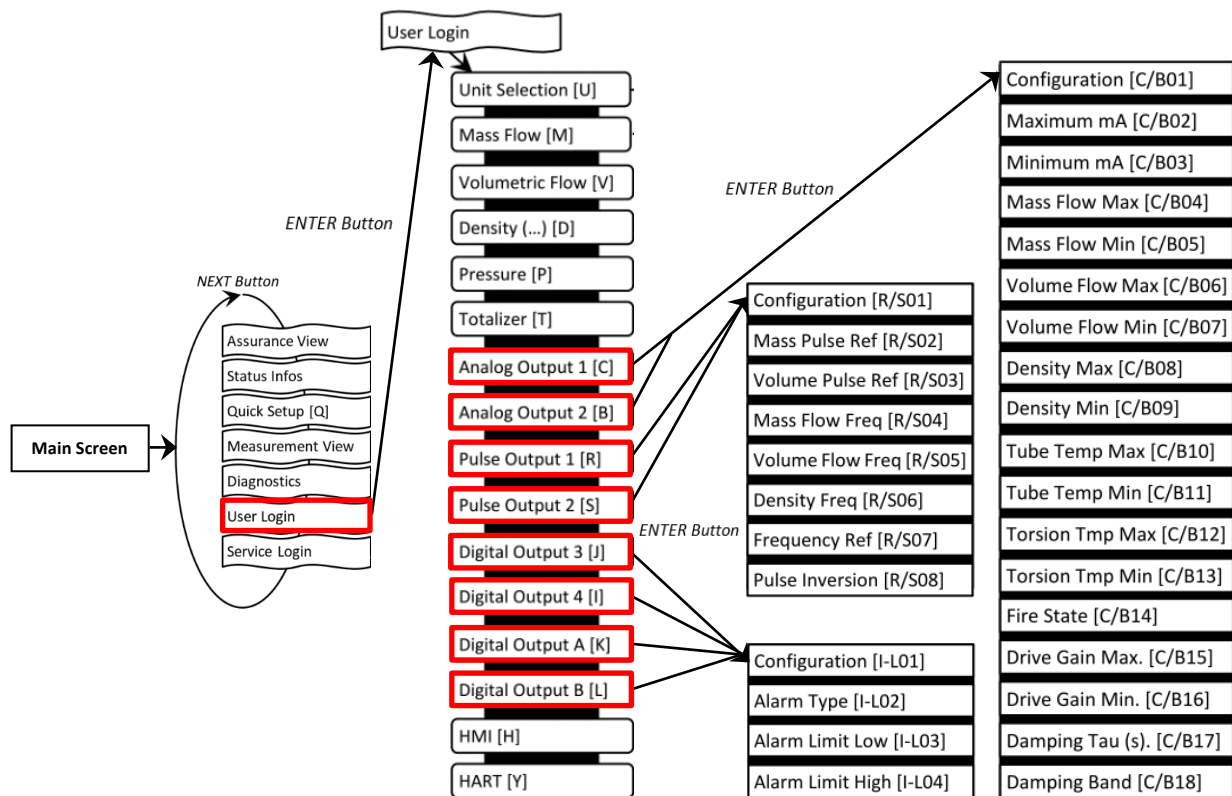

Figure 16: RHE45 Menus - Output Configuration

4.2.5.1 Analog Output Configuration

1. Select “Analog Output” 1 [C] or 2 [B] and press “ENTER” [✓] to get to the “Configuration” [C/B01] menu
2. Select one of the options stated in Table 5 under ID [C/B01], e.g. Configuration 3 – Density
3. The default settings are: “Maximum mA” [C/B02] = 20mA; “Minimum mA” [C/B03] = 4mA. This can be changed if necessary
4. Assign the maximum and minimum of the measured variable to respective mA level, e.g. 1200 kg/m³ for “Density Max” [C/B08] and 0 kg/m³ for “Density Min” [C/B09]
5. Select a fire state configuration [C/B14] to determine what shall happen if the measured variable range is exceeded or in case of error condition
6. If necessary set a damping factor [C/B17] and damping band range [C/B18]

Table 5: Important Analog Output Parameters

ID	Abbreviation	Full Name / Description
[C/B01]	CurOutConfig	Current Output Configuration: Assigns an output channel to the current output: 0 – Analog output is off. 1 – Analog output is configured for Mass Flow (default). → set [C/B04], [C/B05] 2 – Analog output is configured for Volumetric Flow. → set [C/B06], [C/B07] 3 – Analog output is configured for Density. → set [C/B08], [C/B09] 4 – Analog output is configured for Tube Temperature. → set [C/B10], [C/B11] 5 – Analog output is configured for Torsion Bar Temperature. → set [C/B12], [C/B13] 6 – Drive Gain. → set [C/B15], [C/B16]

ID	Abbreviation	Full Name / Description
[C/B14]	CurOutFireState	<p>Current Output Fire State: Determines the behavior (“fail high” or “fail low”) and value of the analog output when the measured variable range is exceeded (values 1 to 5), i.e. the measurement is outside of (CurOutCurMax) and (CurOutCurMin), or an error condition exists in the SoftError or ErrorStatus fields (values 6 to 10). State 0 - Output tracks the signal and clamps at the CurOutMaxCur and CurOutMinCur values when its range is exceeded (default). State 1 - 22 mA = range exceeded State 4 - 3.2 mA = range exceeded State 5 - 3.6 mA = range exceeded State 6 - 22 mA = error condition State 9 - 3.2 mA = error condition State 10 - 3.6 mA = error condition</p>
[C/B17]	CurOutDampingTau	<p>Current Output Damping Tau: Time constant (Tau) of the current output damping in seconds. An exponential damping mechanism is used within a defined band, see CurOutDampingBand. When the output values leave the defined band the damping is disabled. A value of 0.0 disables the damping.</p>
[C/B18]	CurOutDampingBand	<p>Current Output Damping Band: Defines the band range for the damping of the current output in percent of the range between “Minimum mA” [C/B02] and “Maximum mA” [C/B03]. A value of 100 makes sure that the values never leave the band and that the damping always is active.</p>

4.2.5.2 Digital Output Configuration

- Select “Pulse Output” 1 [R], 2 [S] or “Digital Output” A [K], B [L] and press “ENTER” [✓] to get to the “Configuration” [R/S01, I-L01] menu.
The pulse outputs [R,S] can be assigned to a certain pulse rate from a measured value, e.g. the mass flow rate.
The digital outputs [K,L] can be used to indicate status or error.



“Pulse Output” 1 [R] and/or 2 [S] must be disabled if the parameters “Digital Output” A [K] and/or B [L] are assigned to universal digital/pulse outputs

- Select a configuration for the pulse output according to the options stated in Table 10 under ID [R/S01] or for the status output under ID [I-L01]

Examples:

- Configuration of pulse output [R, S] for mass:
 - Select value 1 for parameter ID [R/S01]
 - Acc. to Table 6, the parameter [R/S02] has to be selected. This parameter specifies the mass equivalent to one pulse. E.g. when set to 0.001kg, a mass transfer of 1kg will cause 1000 pulses
- Configuration of a frequency output [R, S] for mass flow rate:
 - Select value 13 for parameter [R/S01]
 - Acc. to Table 6 the parameters [R/S04 & 07] have to be selected. The parameter [R/S04] specifies the mass flow rate equivalent to the frequency set under parameter [R/S07]. E.g. when [R/S04] is set to 1kg/min and [R/S07] is set to 1000Hz a mass flow rate of 5kg/min will cause a frequency of 5000Hz

- c) Configuration of a digital output [I-L] for mass flow alarm:
- Select value 1 for parameter [I-L01]
 - Acc. to Table 6 the parameters [I-L02, 03 & 04] apply. Select the needed alarm type [I-L02] and enter the low [I-L03] and high [I-L04] alarm values. The unit of the alarm is determined by the digital output configuration [I-L01]. For mass flow alarm the unit is fixed to kg/min

Table 6: Important Pulse and Digital Output Parameters

ID	Abbreviation	Full Name / Description
R/S01]	VersDigOutCh0/1Config	<p>Versatile Digital Output Configuration: Used to assign different functions to the pulse output. In simple pulse mode, Pulse1 and Pulse2 operate independently. In phase shift mode, Pulse1 and Pulse2 work together to produce the desired pulse output relationship. In phase shift mode, both outputs (Pulse1 & Pulse2) should be set to the same mode. 0: Pulse output is off. 1: Mass Flow – Simple Pulse, Forward Flow. → set [R/S02] 2: Volume Flow – Simple Pulse, Forward Flow. → set [R/S03] 3: Mass Flow – Pulse1 & Pulse2 90 Degrees phase shift. → set [R/S02] 4: Volume Flow – Pulse1 & Pulse2 90 Degrees phase shift. → set [R/S03] 5: Mass Flow – Simple Pulse, Reverse Flow. → set [R/S02] 6: Volume Flow – Simple Pulse, Reverse Flow. → set [R/S03] 7: Mass Flow Rate Fast Frequency Output. → set [R/S04 & 07] } fast 8: Volumetric Flow Rate Fast Frequency Output. → set [R/S05 & 07] } response 9: Density Fast Frequency Output. → set [R/S06 & 07] } time 10: Mass Flow Rate Slow Frequency Output. → set [R/S04 & 07] } slow 11: Volumetric Flow Rate Slow Frequency Output. → set [R/S05 & 07] } response 12: Density Slow Frequency Output. → set [R/S06 & 07] } time (1s) 13: Mass Flow Rate RHE Compatibility Mode Frequency Output. → set [R/S04 & 07] } Freq. mode of 14: Volume Flow Rate RHE Compatibility Mode Frequency Output. → set [R/S05 & 07] } previous RHE</p>
[I-L01]	DigOutCh0/1/A/BConfig	<p>Digital Output Channel 0 Configuration: Alarm Channel configuration: 0: Error indication (default) 1: Mass flow alarm → set [I-L02, 03 & 04] 2: Volumetric flow alarm → set [I-L02, 03 & 04] 3: Density alarm → set [I-L02, 03 & 04] 4: Tube temperature alarm → set [I-L02, 03 & 04] 5: Torsion bar temperature alarm → set [I-L02, 03 & 04] 6: Pressure Alarm → set [I-L02, 03 & 04] 7: Forward Mass Totalizer TotalMassFwd for Batch Mode → set [I-L02, 03 & 04] 8: Forward Volume Totalizer TotalVolFwd for Batch Mode → set [I-L02, 03 & 04] 9: Fatal errors or Zeroing force output low, else high. 10: Fatal errors or Zeroing force output high, else low. For values 1 to 8, the ERR output is pulled high when the alarm condition specified in DigOutCh0/1/A/BAlmType, DigOutCh0/1/A/B AlmLow, and DigOutCh0/1/A/B AlmHigh becomes true.</p>
[I-L02]	DigOutCh0/1/A/BAlmType	<p>Digital Output Alarm Type: Alarm Channel: Digital Alarm Type: 0: Setpoint alarm (hysteresis, default) – Alarm is indicated when the output is higher than DigOutCh0AlmHigh and cleared when it returns below DigOutCh0AlmLow. 1: Inband alarm – Alarm is indicated when the output is in the range from DigOutCh0AlmLow to DigOutCh0AlmHigh. 2: Outband alarm – Alarm is indicated when the output is outside the range DigOutCh0AlmLow and DigOutCh0AlmHigh. An indicated alarm on channel 0 pulls the digital output 4 labeled “ERR” low.</p>

ID	Abbreviation	Full Name / Description
[I-L03]	DigOutCh0/1/A/BAImLow	Digital Output Alarm Low: Alarm low value, see DigOutCh0/1/A/B AlmType. Must be a floating point value of 0.0 or higher. There is no unit conversion for this register. The unit depends on the DigOutCh0/1/A/B Config setting: 1: kg/min 2: m ³ /min 3: kg/m ³ 4: Degrees Celsius 5: Degrees Celsius 6: Pascal 7: kg 8: m ³ The same units are used for all digital status outputs 0, 1, A, and B depending on DigOutCh0/1/A/BConfig respectively.
[I-L04]	DigOutCh0/1/A/BAImHigh	Digital Output Channel 0 Alarm High: Alarm high value, see DigOutCh0/1/A/BAImType. Must be a floating point value of 0.0 or higher. See DigOutCh0/1/A/BAImLow for the unit specification.

4.2.5.3 Digital Input Configuration

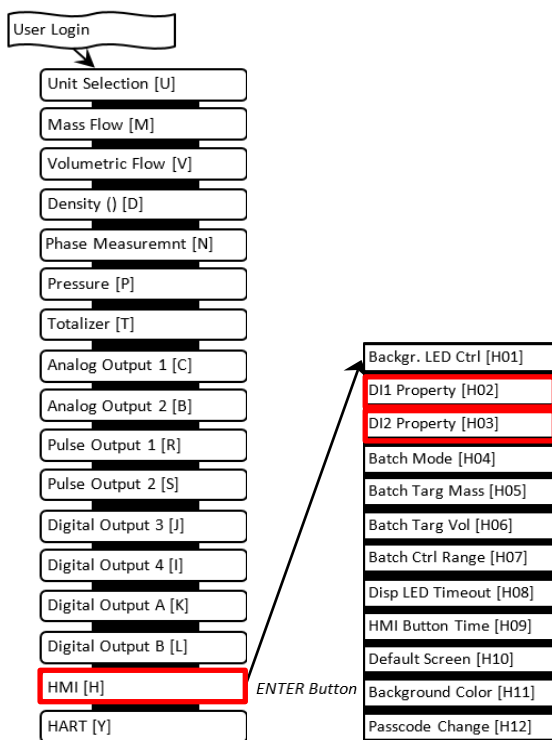

To configure the digital inputs, navigate to the menu item “HMI” under User Login (Figure 17).

1. Select “HMI” [H] and navigate to the “DI1 Property” (digital input 1) [H02] or to the “DI2 Property” (digital input 2) [H03] menu.
2. Select one of the options stated in Table 11.

Figure 17: RHE45 Menu – Digital Output Configuration

Table 7: Digital Input Setting Options

ID	Abbreviation	Full Name / Description
[H02] [H03]	DI1Property DI2Property	Property of Digital Input 1/2: Functionality of Digital Input 1/2: 0: DI1/2 is disabled. All inputs are ignored (default). 1: DI1/2 causes the start of a Zeroing Process. Logic is positive – a transition to a high logic level starts the Zeroing. 2: DI1/2 causes the start of a Zeroing Process. Logic is negative – a transition to a low logic level starts the Zeroing. 3: DI1/2 causes reset of the Totalizers and the start of Batch Processing if configured, see RHE4X Desktop Reference, Batch Mode. Logic is positive – a transition to a high logic level starts the Batch. 4: DI1/2 causes reset of the Totalizers and the start of Batch Processing if configured, see RHE4X Desktop Reference, Batch Mode. Logic is negative – a transition to a low logic level starts the Batch. 5: A transition from low to high at DI1/2 stops the totalizers when they are in the running state. A transition from high to low at DI1/2 restarts the totalizers when they are in the stopped state. 6: A transition from high to low at DI1/2 stops the totalizers when they are in the running state. A transition from low to high at DI1/2 restarts the totalizers when they are in the stopped state.

4.3 Operation and Configuration via USB or RS485

If the RHE45 is connected via RS485, we recommend making all setup via RS485, if possible via the remote control SW RHEComPro.

If there is no RS485 connected, you can use the internal Mini USB interface.



The RHE45 must not be opened in wet or dirty (dusty) ambient or when the housing of the RHE45 is wet.

For setting up the RHE45 via the internal USB interface proceed as follows:

- Open the top cover of the RHE by removing the 4 screws in the corners of the top cover.
- Connect the USB to a PC, preferable to a laptop.
- Start RHEComPro on the laptop. For more information about installation and usage of the RHEComPro refer to the manual of the RHEComPro.
- Connect to the RHE45 by clicking on “Connect”. If the SW does not find the RHE45, try a different COM port.
- After having finished the setup disconnect the RHE45 in RHEComPro (ikon in left sidebar), remove the USB cable and reclose the RHE45.
- Make sure that the top cover gets properly closed for achieving the IP protection.

4.3.1 Zero Offset Calibration

After installation of the RHM with RHE45 a zero calibration is strongly recommended.

- Flush the RHM with the fluid to be measured and make sure that the RHM is 100% filled.
- Operate the RHE45 for at least 15 minutes for warming up.
- Stop the flow and make sure that there is no more flow. For best results a valve in front and behind the RHM would be recommended.
- Click 2 times on the arrow in the right upper corner of the RHEComPro main display.
- Click on “Make Zero” in the right lower corner of the RHEComPro display. The field “Zero” gets yellow and the time counter counts down to zero.
- When the counter stops at zero and the field “zero” returns to green, reopen the valves for normal operation.

4.3.2 Input/Output Configuration

The RHEComPro has a menu for configuring the outputs. The menu is self-explaining and no special knowledges are required.

Proceed as follows:

- Click on “Configuration” on top of the RHEComPro main display.
- Select the input or output to be configured and follow the explanations in the menu.
- After “OK” or “Cancel” at the end the RHEComPro returns to normal operation.

4.3.3 I/O test

For a fast check of the I/O connections between the RHE45 and the SPS/PLC, the RHEComPro provides an I/O test menu.

For testing the I/O connections proceed as follows:

- Click on “Maintenance” on top of the RHEComPro main display.
- Select “Standard Maintenance Activities”
- Select “Fast Tests for I/O”
- Select the output to be tested and follow the explanations in the menu.
- After “Exit the Test” the RHEComPro returns to normal operation.

4.3.4 Internal System Time

The RHE45 has a build in real time clock (RTC) which is useful for data logging or zero history.

For further information please refer to the RHE4X Desktop Reference manual.



The RHE45 does not feature a backup battery. The date and time must be updated after every system start or reset.

5 Remote Operation

RHE45 transmitters have a USB interface for fast setup or trouble shooting and an RS485 interface for digital communication, remote control and data exchange.

Optionally Modbus TCP, EtherNet/IP, ProfiNet, Profibus DP and EtherCAT are available.

5.1 USB

The USB interface is designed for temporary connection of a PC running RHEComPRO software for setup, configuration, troubleshooting and data logging.

Connection to the USB interface is by Mini-USB cable to a PC-based computer.

For installing, starting and operating the RHECom software please refer to the RHEComPro Suite User Manual and the RHE4X Desktop Reference manual.

5.2 RS485

The RS485 port uses Modbus protocol for permanent connection to a supervisory control system.

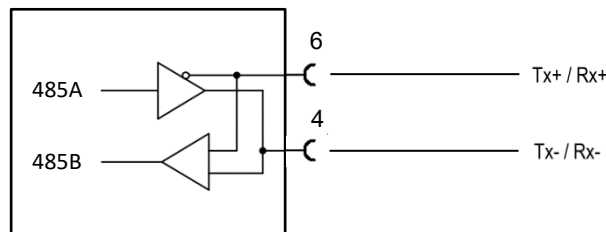

Figure 18: RS485 interface wiring

For using Modbus via the RS485 serial port, refer to the RHE45 Desktop Reference Manual for a detailed description of the interface and register set.

The RHE45 has an internal 120Ω termination resistor for the RS485. This resistor can be disconnected via a switch. Ex works the resistor is connected (switch position “ON”).

In a point to point connection of the RS485 the termination resistor is required for cable length of more than about 5m.

In a chain connection the resistor must be “ON” at the last device in the chain and “OFF” at all devices in between.

For accessing the switch refer to chapter 4.1.2.

5.3 Modbus TCP (I/O options EA and EB)

The options EA or AB provide one Ethernet 100base TX port and the digital input DI2 on the 8-pin M12 socket.

Table 8 shows the pinning of the M12 connector, the cable colors (accessory ARHE45-M2) and the RJ45 pinning.

Table 8: 8-Pin M12 Socket Configuration for Options EA, EB and RJ45 wiring

M12 Pin #	Signal	CAT5 Coloring	RJ45 Pin #, Name
1	-	white/blue	
2	DI2, digital input 2	white/brown	
3	I/O GND	brown	
4	Eth 1 TX-	orange	2, D1-
5	Eth 1 RX+	white/green	3, D2+
6	Eth 1 TX+	white/orange	1, D1+
7	-	blue	
8	Eth 1 RX-	green	6, D2-
Shield	Ground / PE		Shield



Make sure that the digital input DI2 (pin 2 and 3) gets not connected to any Ethernet signal. Otherwise the RHE45 might not work properly.

For further information please refer to the RHE4X Desktop Reference manual.

5.4 EtherNet/IP, ProfiNet and EtherCAT (I/O options EN, EP and EC)

The options EN, EP, and EC provide two Ethernet 100base TX port on the 8-pin M12 socket.

For easiest connection to the Ethernet use the connection cable ARHE45-MY.

Table 9 shows the pinning of the M12 connector, the cable colors (ARHE45-MY) and the RJ45 pinning.

Table 9: 8-pin M12 Socket Configuration for Options EN, EP, EC and RJ45 wiring

M12 Pin #	Signal	CAT5 Coloring	1 st RJ45 Pin #, Name	2 nd RJ45 Pin #, Name
1	Eth 2 TX-	white/blue		2, D1-
2	Eth 2 RX+	white/brown		3, D2+
3	Eth 2 RX-	brown		6, D2-
4	Eth 1 TX-	orange	2, D1-	
5	Eth 1 RX+	white/green	3, D2+	
6	Eth 1 TX+	white/orange	1, D1+	
7	Eth 2 TX+	blue		1, D1+
8	Eth 1 RX-	green	6, D2-	
Shield	Ground / PE		Shield	Shield

These fieldbus interface offer a limited access mainly to the measurement data maintained by the RHE transmitter. Following measurement data items are available to be read out periodically:

Index	Modbus Name	Modbus Reference	Type
256	ErrorStatus	See Generic / 0x401A.	Unsigned32
257	SoftError	See Generic / 0x401C.	Unsigned32
258	Warnings	See Generic / 0x401E.	Unsigned32
259	InfoStatus	See Generic / 0x4020.	Unsigned32
260	DenComp	See Density / 0x4806.	Float32
261	MassFlowRate	See Mass Flow / 0x4900.	Float32
262	VolumetricFlowRate	See Volumetric Flow / 0x4A00.	Float32

Index	Modbus Name	Modbus Reference	Type
263	TotalMassFwd	See Totalizer / 0x4B00.	Float32
264	TotalVolFwd	See Totalizer / 0x4B02.	Float32
265	TotInvenMassNet	See Totalizer / 0x4B04.	Float32
266	TotInvenVolNet	See Totalizer / 0x4B06.	Float32
267	TotalMassRev	See Totalizer / 0x4B08.	Float32
268	TotalVolRev	See Totalizer / 0x4B0A.	Float32
269	AdcTubeMeanTemp	See Temp. Measurement / 0x4500.	Float32
270	AdcTorBarMeanTemp	See Temp. Measurement / 0x4502.	Float32
271	OnBrdTemp	See Temp. Measurement / 0x4504.	Float32
272	PrsMean	See Pressure / 0x4604 (RHE2X).	Float32
273	AssuranceFactor	See Generic / 0x4026 (RHE2X).	Float32
274	StdDensity	See Density / 0x480A.	Float32
275	VolPercentMainSubstance	See Density / 0x480C.	Float32
276	MassFlowRateDisplay	See Mass Flow/0x4904	Float32
277	VolumetricFlowRateDisplay	See Volume Flow/0x4A02	Float32

The measurement data is expanded by their unit codes and unit strings added for convenience. These are intended to be read out at the startup of a system:

Index	Modbus Name	Modbus Address	Type
320	TemperatureUnit	0x6100	Unsigned32
321	PressureUnit	0x6102	Unsigned32
322	MassUnit	0x6104	Unsigned32
323	MassFlowUnit	0x6106	Unsigned32
324	DensityUnit	0x6108	Unsigned32
325	VolumeFlowUnit	0x610A	Unsigned32
326	VolumeUnit	0x610C	Unsigned32
327	TemperatureUnitString		Octet String
328	PressureUnitString		Octet String
329	MassUnitString		Octet String
330	MassFlowUnitString		Octet String
331	DensityUnitString		Octet String
332	VolumeFlowUnitString		Octet String
333	VolumeUnitString		Octet String

The unit strings are 8 characters long and not 0-terminated. They are encoded in the ISO 8859-1 character set and contain special characters such as ‘’ or ‘²’ which must be translated to the target character encoding used for the display of strings.

Further output data items are specified which can be read or written and can used to influence the RHE transmitter. These are shown in the following table:

Index	Modbus Name	Modbus Address	Type
384	UserPassword	0x6004	Octet String (0x0A) (4 ASCII Characters)
385	TotInvenReq	0x6B00	Unsigned32 (0x07)
386	ZeroingRequest	0x6718	Unsigned32 (0x07)
387	Squawk	0x6F1C	Unsigned32 (0x07)

Before a Zeroing or the Squawk function can be initiated the currently valid user password has to be written to the UserPassword data item. The default user password is “1111”

For further information on the referenced data items please refer to the RHE4X Desktop Reference manual.

The ProfiNet and EtherNet/IP interfaces also offer a transparent access to a Modbus TCP protocol which facilitates the access to all the configuration parameters of the RHE transmitter, e.g. with the help of the RHEComPro program. This may be used in the system commission phase via the same 100 Base TX ports used for the fieldbus accesses. The port number for the Modbus TCP protocol is defined in the setup register Modbus_TCP_Port (0x60C0). By default this register is set to 502, the standard Modbus port number.

5.4.1 ProfiNet Specific Information

The two 100 Base TX interfaces present for ProfiNet can be used to implement an S2 System Redundancy. The standard GSDML file is already prepared for this option. Rheonik was assigned the Vendor ID 0x056C and the RHE4X transmitter series got the Device ID 0x0001. Whilst the employed ProfiNet module supports isochronous transfers (IRT), this feature is not used since the mass flow measurements are done independently from any master synchronization.

When no dedicated IP address is specified in the setup register IPv4_Addr (0x60C2) there are several possibilities to assign an IP address to the ProfiNet interface:

- DCP (ProfiNet)
- Secure HICP
- SNMP
- DHCP

When an IP address has been assigned the selection of the IP address assignment method also can be done via the onboard HMTL pages. Thus, a preliminary IP address may be set via IPv4_Addr, the assignment method selected via the HMTL pages and thereafter a reset of IPv4_Addr to 0.0.0.0 will activate the assignment method. If security concerns are an issue, please configure the SNMP interface with an appropriate password.

All cyclic measurement values listed above in the index range of 256 to 277 are accessed via the API=0/Slot=0/Subslot=1 address tuple and the index of the data item as specified above. These data items are also included in the GSDML file.

The other registers with indices higher than 319 contain acyclic data which have to be accessed by the ProfiNet “Get Record” or “Set Record” commands. They are located in the same API=0/Slot=0/Subslot=1 address tuple.

The data area layout for the periodic data is available as General Station Description (GSDML) file which can be obtained from the Rheonik Service.

5.5 Profibus DP (I/O option DP)

The option DP provides one Ethernet 100base TX port and the digital input DI2 on the 8-pin M12 socket.

Table 10 shows the pinning of the M12 connector, the cable colors (accessory ARHE45-M2) and the recommended standard pinning of a 9-pin D-Sub connector.

Table 10: 8-pin M12 Socket Configuration for Option DP

M12 Pin #	Signal	CAT5 Coloring	Reference 9-pin Sub-D
1	-	white/blue	
2	DI2, digital input 2	white/brown	
3	I/O GND	brown	
4	BUS_A (RS485-)	orange	3
5	+5V	white/green	6
6	BUS_B (RS485+)	white/orange	8
7	-	blue	
8	DGND	green	5
Shield	Ground / PE		Shield (1)

The PROFIBUS station address may be set from the master using the PROFIBUS identification of the RHE. This is currently 0xA56. An initial station address may be set in the RHE parameter set in the following Modbus holding register:

Address	Register Name	Type	Description
0x60CC	FieldbusNodeId	UINT32	Values in the range of 0 to 125 set the node address, other values assume the use of SSA.

All measurement data items transferred on the PROFIBUS interface are 4-byte entities and are of unsigned integer or IEEE 754 32-bit floating point type. These are transferred in big endian byte ordering.

The layout of the measurement-related SDO data and the default PDO area is shown in the following table:

Rd_Inp (SAP56) offset	Slot / Index	Modbus Name	Modbus Reference	Type
0	1 / 0	ErrorStatus	See Generic / 0x401A.	Unsigned32 (0x07)
4	1 / 1	SoftError	See Generic / 0x401C.	Unsigned32 (0x07)
8	1 / 2	Warnings	See Generic / 0x401E.	Unsigned32 (0x07)
12	1 / 3	InfoStatus	See Generic / 0x4020.	Unsigned32 (0x07)
16	1 / 4	DenComp	See Density / 0x4806.	Floating Point (0x08)
20	1 / 5	MassFlowRate	See Mass Flow / 0x4900.	Floating Point (0x08)
24	1 / 6	VolumetricFlowRate	See Volumetric Flow / 0x4A00.	Floating Point (0x08)
28	1 / 7	TotalMassFwd	See Totalizer / 0x4B00.	Floating Point (0x08)
32	1 / 8	TotalVolFwd	See Totalizer / 0x4B02.	Floating Point (0x08)
36	1 / 9	TotInvenMassNet	See Totalizer / 0x4B04.	Floating Point (0x08)
40	1 / 10	TotInvenVolNet	See Totalizer / 0x4B06.	Floating Point (0x08)
44	1 / 11	TotalMassRev	See Totalizer / 0x4B08.	Floating Point (0x08)
48	1 / 12	TotalVolRev	See Totalizer / 0x4B0A.	Floating Point (0x08)
52	1 / 13	AdcTubeMeanTemp	See Temp. Measurement / 0x4500.	Floating Point (0x08)
56	1 / 14	AdcTorBarMeanTemp	See Temp. Measurement / 0x4502.	Floating Point (0x08)
60	1 / 15	OnBrdTemp	See Temp. Measurement / 0x4504.	Floating Point (0x08)
64	1 / 16	PrsMean	See Pressure / 0x4604 (RHE2X).	Floating Point (0x08)

Rd_Inp (SAP56) offset	Slot / Index	Modbus Name	Modbus Reference	Type
68	1 / 17	AssuranceFactor	See Generic / 0x4026 (RHE2X).	Floating Point (0x08)
72	1 / 18	StdDensity	See Density / 0x480A.	Floating Point (0x08)
76	1 / 19	VolPercentMainSubstance	See Density / 0x480C.	Floating Point (0x08)
80	1 / 20	MassFlowRateDisplay	See Mass Flow/0x4904	Floating Point (0x08)
84	1 / 21	VolumetricFlowRateDisplay	See Volume Flow/0x4A02	Floating Point (0x08)

The measurement data is expanded by their unit codes and unit strings added for convenience:

Slot / Index	Modbus Name	Modbus Address	Type
1 / 64	TemperatureUnit	0x6100	Unsigned32 (0x07)
1 / 65	PressureUnit	0x6102	Unsigned32 (0x07)
1 / 66	MassUnit	0x6104	Unsigned32 (0x07)
1 / 67	MassFlowUnit	0x6106	Unsigned32 (0x07)
1 / 68	DensityUnit	0x6108	Unsigned32 (0x07)
1 / 69	VolumeFlowUnit	0x610A	Unsigned32 (0x07)
1 / 70	VolumeUnit	0x610C	Unsigned32 (0x07)
1 / 71	TemperatureUnitString		Octet String (0x0A)
1 / 72	PressureUnitString		Octet String (0x0A)
1 / 73	MassUnitString		Octet String (0x0A)
1 / 74	MassFlowUnitString		Octet String (0x0A)
1 / 75	DensityUnitString		Octet String (0x0A)
1 / 76	VolumeFlowUnitString		Octet String (0x0A)
1 / 77	VolumeUnitString		Octet String (0x0A)

The unit strings are 8 characters long and not 0-terminated. They are encoded in the ISO 8859-1 character set and contain special characters such as ‘*’* or ‘*²*’ which must be translated to the target character encoding used for the display of strings.

Further output data items are specified which can be used to influence the RHE transmitter. These are shown in the following table:

Slot / Index	Modbus Name	Modbus Address	Type
1 / 128	UserPassword	0x6004	Octet String (0x0A) (4 ASCII Characters)
1 / 129	TotInvenReq	0x6B00	Unsigned32 (0x07)
1 / 130	ZeroingRequest	0x6718	Unsigned32 (0x07)
1 / 131	Squawk	0x6F1C	Unsigned32 (0x07)

Before a Totalizer Reset or a Zeroing can be initiated the currently valid user password has to be written to the UserPassword data item.

The entire data area layout is available as General Station Description (GSD) file which can be obtained from the Rheonik Service.

For further information please refer to the RHE4X Desktop Reference manual.

6 Service and Maintenance

6.1 Maintenance and Calibration

RHE45 and the associated RHM flow sensor do not require any regular maintenance. In harsh environments or if highest accuracy is required we recommend a calibration every 2 years.

For the calibration procedure refer to the RHE4X Desktop Reference Manual and/or contact Rheonik or your local dealer.

For best performance the zero point calibration should be performed from time to time or when the meter shall be used under drastically changed operating conditions (temperature, density, pressure...).

6.2 Supervision and Troubleshooting

Remote operation:

On the page “Diagnosis” of the RHEComPro (one click left from the main screen) the stability data and the error status can be checked.

RHE45 with display:

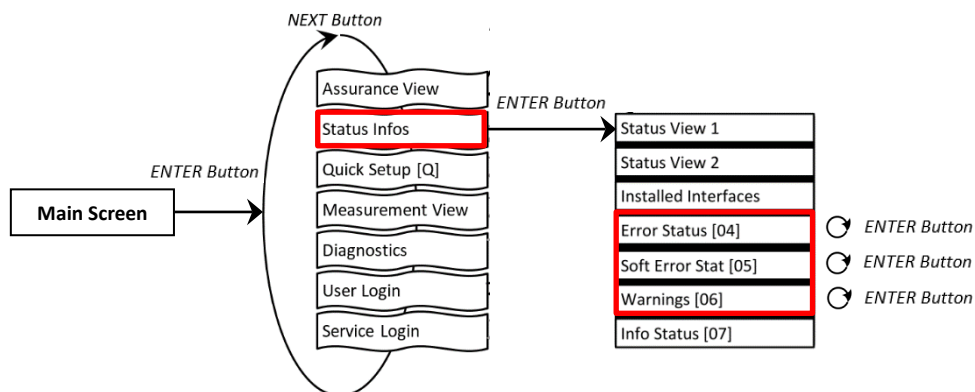

Figure 19: Error / Warning Status

Each status window shows a code e.g. ‘0x00000000’. By pressing the ENTER button, the cursor walks through this code from right to left. The respective error or warning bit is explained at the bottom of the display.

For detailed assistance, please refer to the troubleshooting section of the RHE4X Desktop Reference. This chapter contains comprehensive information on understanding and troubleshooting errors, warnings and connection issues with the flow meter.

6.3 Service

RHE45 transmitters do not contain any user serviceable parts. Please contact your local sales/support agent or Rheonik Support for assistance.

6.4 WEEE and RoHS

RHE45 transmitters are not subject to the WEEE directive and are fully compliant to the RoHS directive.

7 Ordering Code

Construction Type

- C1 Compact Mount at Sensor IP66 - M12 socket (requires sensor connection option J5)
- CD Compact Mount with display at Sensor IP66 - M12 socket connectors (requires sensor connection option J5)

Supply Voltage

- D1 12 to 24 VDC ($\pm 10\%$)

Software Function Package

- SO Standard OP system - mass flow, normalized density / volume
- DO Enhanced OP system - mass flow, measured density / volume - requires RHM density calib.
- AF Enhanced OP system plus Assurance Factor®, data logging, partly filled pipe manager etc.

I/O Configuration

- B1 RS485 (Modbus RTU), 2 x DO (pulse/freq./status), 1 x DI - 1x M12-12 pin
- P1 RS485 (Modbus RTU), 1 x 4-20mA (passive), 2 x DO (pulse/freq./status), 1 x DI - 1x M12-12 pin
- P2 RS485 (Modbus RTU), 2 x 4-20mA (passive), 2 x DO (pulse/freq./status), 1 x DI - 1x M12-12 pin
- S1 RS485 (Modbus RTU), 1 x 4-20mA (active), 2 x DO (pulse/freq./status), 1 x DI - 1x M12-12 pin
- S2 RS485 (Modbus RTU), 2 x 4-20mA (active), 2 x DO (pulse/freq./status), 1 x DI - 1x M12-12 pin
- EB Modbus TCP, 2 x DO (pulse/freq./status), 2 x DI - 1x M12-12 pin, 1x M12-8 pin
- EA Modbus TCP, 2 x 4-20mA (active), 2 x DO (pulse/freq./status), 2 x DI - 1x M12-12 pin, 1x M12-8 pin
- EN Ethernet IP, Modbus IP, 2 x DO (pulse/freq./status), 1 x DI - 1x M12-12 pin, 1x M12-8 pin
- EP Profinet, 2 x DO (pulse/freq./status), 1 x DI - 1x M12-12 pin, 1x M12-8 pin
- EC EtherCAT, 2 x DO (pulse/freq./status), 1 x DI - 1x M12-12 pin, 1x M12-8 pin
- EL PowerLink, 2 x DO (pulse/freq./status), 1 x DI - 1x M12-12 pin, 1x M12-8 pin
- DP Profibus DP, 2 x DO (pulse/freq./status), 2 x DI - 1x M12-12 pin, 1x M12-8 pin
- DN DeviceNet, 2 x DO (pulse/freq./status), 2 x DI - 1x M12-12 pin, 1x M12-8 pin
- DC CAN, 2 x DO (pulse/freq./status), 2 x DI - 1x M12-12 pin, 1x M12-8 pin
- DO CAN Open, 2 x DO (pulse/freq./status), 2 x DI - 1x M12-12 pin, 1x M12-8 pin
- XX Customized Configuration of I/O Interface

Hazardous Area Approval

- NN For Installation in Safe Area

RHE45 - - NN - NNN

8 Accessories

For tests, test installations, and as a reference Rheonik offers a small number of accessories fitting to the two M12 sockets of the RHE45.

Table 11: RHE45 Accessories

Order Code	Description	Exemplary Pictures
ARHE-SO	RHECom Software on USB flash drive	-
ARHE-RS	Interconnection Cable RHE45 to PC, 5m (Mini-USB to PC USB)	
ARHE-MO	Adapter Modbus RS485 to USB with Interface Cable, 2m Accessory ARHE45-MS recommended for connection to RHE45	
ARHE45-M1	Shielded 12-core Cable with 12-Pin M12 Plug, 3m	
ARHE45-M2	Shielded 8-core Cable with 8-Pin M12 Plug, 2m	
ARHE45-MS	Shielded Cable with 12-Pin M12 Plug and Test Interface, 3m	
ARHE45-MY	Shielded CAT5 Cable for two Ethernet 100Base TX Interfaces with RJ45 Sockets, 2m	

Appendix A Technical Information

A.1 Technical Data

General Data	
Housing:	Closed Box, directly mounted to the RHM
Material:	Aluminum, powder coated
Enclosure Rating:	IP65; up to IP67 upon request
Ambient Temperature:	-40°C to +60°C (-44°F to +140°F)
Humidity:	10 to 90% relative humidity, non-condensing
Altitude:	Up to 3000m, higher maximum altitude upon request
Dimensions:	See drawing chapter B.2
Weight:	0.5kg
Display:	Optionally - high contrast backlit LCD, screen changes color to indicate warning or error
Operation:	Via remote control
Power Supply:	DC: 12-24 VDC +/- 10%, 6W
Connection:	Connectors M12 / 12 pin and M12 / 8pin
Interfaces:	Modbus RTU (RS485) and USB (standard) Modbus TCP, Ethernet/IP, ProfiNet, Profibus DP, EtherCAT (option)
Analog Outputs	
Type:	4-20mA compliant to NAMUR NE-43
Signal type and quantity:	0, 1 or 2, passive floating and active referenced to GND, type and quantity depending on I/O type
Output value:	Programmable
Digital Universal Outputs	
Output signal:	Pulse, Frequency, Status
Type:	24V push-pull, according to IEC60946
Maximum current:	50mA
Frequency range:	0 ... 10 kHz
Quantity:	2
Output value:	Programmable

Digital Inputs

Type: 24V, according to IEC60946

Input Level: >13V for high state, < 6V for low state

Input Current: 1mA

Quantity: 1 to 2

Input value: Programmable

A.2 Mechanical Drawing

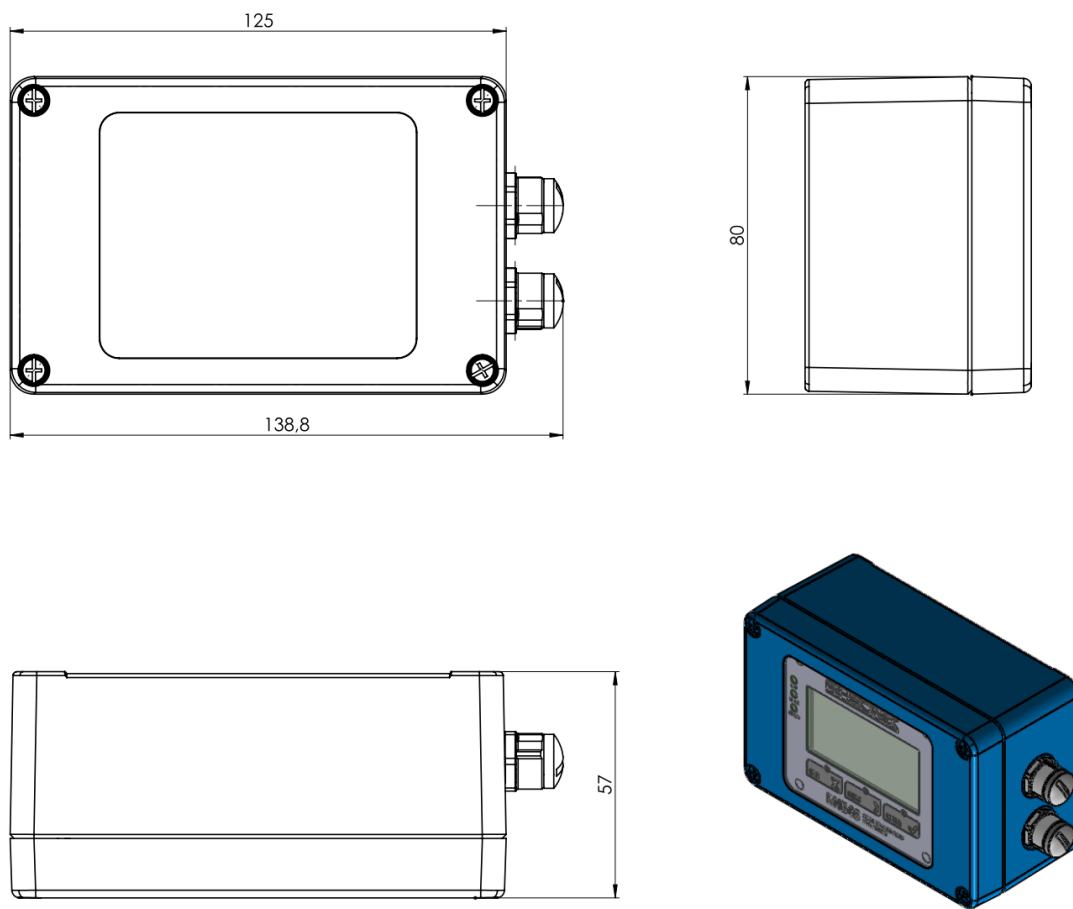

RHE45 Transmitter Box Dimensions (all dimensions in mm)

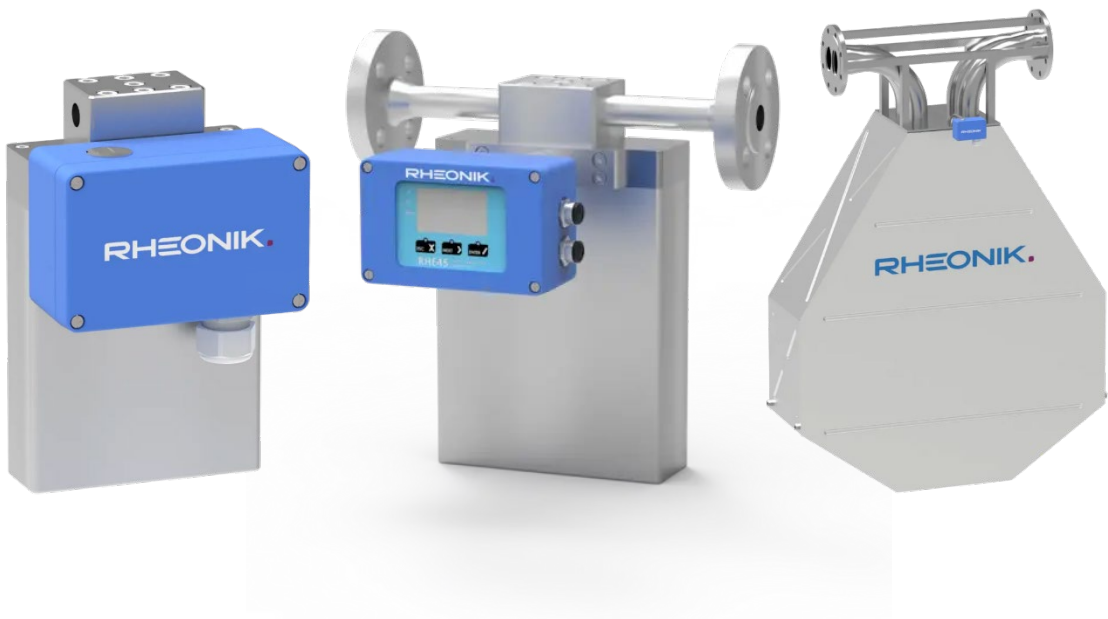

For detailed drawings and dimensions please refer to the RHM data sheets.

Appendix B CE Certificate



DECLARATION OF CONFORMITY

Equipment: RHE45-****-****-NN**-*** Coriolis mass flow transmitter

Manufacturer: Rheonik Messtechnik GmbH
Address: Rudolf-Diesel-Str. 5
D-85235 Odelzhausen, Germany

We declare in sole responsibility that the above-mentioned equipment is in conformity with the following directives and standards:

European Directives: 2014/30/EU (EMC)
2011/65/EU (RoHS)

Applicable Standards: EN 61326-1:2013 EN 55011:2018
EN 61010-1:2020
EN 61000-6-2:2019
EN 61000-6-4:2020

EMC: EN 55011:2018, Group 1, Class B
EN 61326-1:2013; Class A

Certification type and Marking: 

Notified body for ISO 9001: TÜV NORD CERT GmbH
45307 Essen
Accr. Number: D-ZM-12007-01-00

Issue Date: 21. October 2022

Signatory:



Kay Stegmann Date
Electronics Engineering Manager



Uwe Hettrich Date
Managing Director



About Rheonik

Rheonik has but one single purpose: to design and manufacture the very best Coriolis meters available.

Our research and engineering resources are dedicated to finding new and better ways to provide cost effective accurate mass flow solutions that provide value to our customers. Our manufacturing group care for each and every meter we produce from raw materials all the way to shipping, and our service and support group are available to help you specify, integrate, start-up and maintain every Rheonik meter you have in service. Whether you own just one meter or have hundreds, you will never be just another customer to us. You are our valued business partner.

Need a specific configuration for your plant? Don't compromise with a "standard" product from elsewhere that will add extra cost to your installation. If we can't configure it from our extensive and versatile product range, our exclusive **AnyPipeFit Commitment** can have your flow sensor customized with any size/type of process connection and face to face dimension you need.

No matter what control system you use as the backbone in your enterprise, with our **AnyInterface Commitment**, you can be sure that connection and communication will not be a problem. Alongside a wide variety of discrete analog and digital signal connections, we can also provide just about any network/bus interface available (for example: HART, ProfibusDP, ProfiNet, EtherCAT, PowerLink, EtherNet/IP, CAN,) with our RHE 40 Series family of transmitters. Rheonik RHE 40 Series transmitters can connect to your system – no headache and no conversion needed.

Rheonik Messtechnik GmbH
Rudolf-Diesel-Straße 5
D-85235 Odelzhausen
Germany

Tel. + 49 (0)8134 9341-0
info@rheonik.com

