

Mark 601/602 Series

High Flow Pressure Regulators

The Mark 601 and 602 meet higher capacity requirements than standard regulators. The High Flow Mark 601 has Cv's as high as 50 (43 Kv) and the Super High Flow Mark 602 has Cv's up to 70 (60,2 Kv). Each valve is standard with Jordan's Sliding Gate Seats, which helps to reduce the droop commonly associated with high flow regulators.

Jordan's unique self-operated sliding gate pressure regulator offers:

- Shorter stroke than a globe or plug-style valve
 - Faster response
 - Less offset
 - Smaller and lighter weight than globe-style valves
 - Longer diaphragm life
- Straight-through flow
 - Less turbulence, erosion and noise
 - Improved rangeability
 - Longer seat life
- Ease of maintenance
 - Interchangeable seats and Cv's
 - Fewer spare parts
 - Self-cleaning seats
 - No gaskets or o-rings

SPECIFICATIONS

Sizes: 1-1/2" & 2" (DN40 & DN50)

End Connections:

- Threaded – NPT, BSPT, BSPP
- ANSI Flanges (150#, 300#)
- DIN Flanges (PN 10/16, PN 25/40)

Body Materials

- Ductile Iron
- Bronze
- Carbon Steel (A216 WCB)
- Stainless Steel (A351/CF8M)

Trim Materials

- 303SST – Standard on Ductile Iron, Bronze, Carbon Steel valves
- 316SST – Standard on Stainless Steel valves
- Monel, Hastelloy and other Alloys available



Seat Materials

- Jorcote on SST – Standard

Diaphragm Materials

- Stainless Steel – standard
- Jorlon – standard
- Buna-N – optional
- Viton – optional

Service: Steam, water, oil, gas, air and chemicals

Shutoff: ANSI Class IV

Reduced Pressure Control Ranges: Select a range to match your setpoint. For optimal performance, your setpoint should fall in the upper portion of the selected range.

Model	Size (DN)	Spring Ranges	
		PSI	Bar
601 & 602	1-1/2" – 2" (DN40 – DN50)	20 – 45	1,4 – 3,1
		30 – 95	2,1 – 6,6
		60 – 160	4,1 – 11,0

Cv Values & Maximum Differential Pressures

- Mark 601

Cv (Kv)	Size (DN)	Seat Material	Maximum ΔP PSI (BAR)
25 (21,5)	1-1/2" & 2" (DN40 & DN50)	Jorcote	150 (10,3)
30 (25,8)	1-1/2" & 2" (DN40 & DN50)	Jorcote	150 (10,3)
3 5 (30,1)	1-1/2" & 2" (DN40 & DN50)	Jorcote	150 (10,3)
45 (38,7)	1-1/2" (DN40)	Jorcote	150 (10,3)
50 (43,0)	2" (DN50)	Jorcote	150 (10,3)

- Mark 602

Cv (Kv)	Size (DN)	Seat Material	Maximum ΔP PSI (BAR)
65 (56)	1-1/2" (DN40)	Jorcote	150 (10,3)
70 (60)	2" (DN50)	Jorcote	150 (10,3)

DIMENSIONS – MARK 601/602

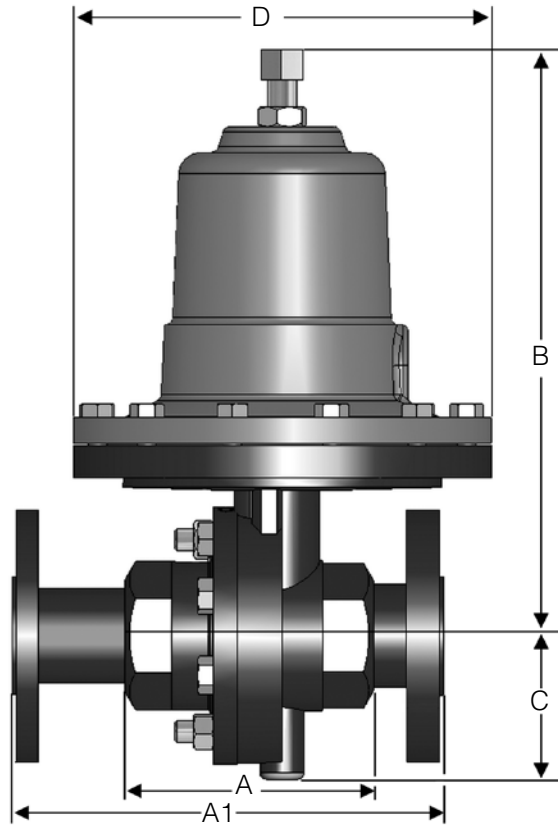

• Threaded & FSW Ends, Inches

Size	Material	A	B	C	D	Weight (lbs)
1-1/2" & 2"	DI/BRZ	4.50	11.50	2.75	7.09	26
	CS/SS	5.50	11.75	2.75	7.09	35

• Threaded & FSW Ends, Metric

Size	Material	A	B	C	D	Weight (kgs)
DN40 - 50	DI/BRZ	114	292	70	180	11,7
	CS/SS	140	298	70	180	15,9

• Flanged Ends, Inches

Size	ANSI Flange	A1		B		C	D	Weight (lbs)	
		DI/BRZ	CS/SS	DI/BRZ	CS/SS	ALL	ALL	DI/BRZ	CS/SS
1-1/2" ¹	150#	10.00	10.00	11.50	11.75	2.31	7.09	42	46
	300#	10.25	10.25	11.50	11.75	2.31	7.09	45	52
2" ²	150#	10.00	10.00	11.50	13.25 ²	2.75	7.09	46	50
	300#	10.50	10.50	11.50	13.25 ²	2.75	7.09	49	55

¹ Not ANSI Standard

² IFE only

• Flanged Ends, Metric

Size	ANSI Flange	A1		B		C	D	Weight (kgs)	
		DI/BRZ ²	CS/SS	DI/BRZ	CS/SS	ALL	ALL	DI/BRZ	CS/SS
DN40 ¹	10/16	254	254	292	298	70	180	19,1	20,9
	25/40	260	260	292	298	70	180	20,4	23,6
DN50	10/16	254	230 ²	292	336 ²	70	180	20,9	22,7
	25/40	268	230 ²	292	336 ²	70	180	22,2	24,9

¹ Not per DIN3202

² IFE only

ORDERING SCHEMATIC

Model No	Size	Body Mat'l	1	2	3	4	5	6	7	8	9	10	11	12	13	14	15

Model	
601	High Flow
602	Super High Flow

Size	
150	1-1/2" (DN40)
200	2" (DN50)

Body Material	
DI	Ductile Iron
BR	Bronze
CS	Carbon Steel
S6	Stainless Steel

1 & 2	End Connections
PT	NPT
BT	BSPT
I5	150# IFE, CS or SST*
F5	150# FE, DI or BR
I7	PN10 IFE, CS or SST*
F7	PN10 FE, DI or BR
I6	PN16 IFE, CS or SST*
F6	PN16 FE, DI or BR
BP	BSPP
SW	FSW
I3	300# IFE, CS or SST*
F3	300# FE, DI or BR
I8	PN25 IFE, CS or SST*
F8	PN25 FE, DI or BR
I4	PN40 IFE, CS or SST*
F4	PN40 FE, DI or BR

3 & 4	Trim
S3	303SS
S6	316SS
I3	303SSF/IFE (1/2" - 2" CS/S6)
I6	316SSF/IFE (1/2" - 2" CS/S6)

5	Seat Material
Q	303SST/Teflon Coated
R	316SST/Teflon Coated
V	303SS/Jorcote
W	316SS/Jorcote

6	Cv (Kv)
A	25 (22)
B	30 (26)
V	35 (30)
W	45 (39)
C	50 (43)
Y	65 (56)
E	70 (60)

7 & 8	Spring Range PSI (Bar)
53	20 - 45 (1,4 - 3,0)
75	30 - 95 (2,1 - 6,6)
97	60 - 160 (4,1 - 11,0)

9 & 10	Diaphragm
S6	316SST
V _I	Viton
BN	Buna-N
JL	Jorlon

11 & 12	Actuator
MD	DI for Metal Diaphragm
ED	DI for Elastomer Diaphragm
SM	316 for Metal Diaphragm
SE	316 for Elastomer Diaphragm

13 & 14	Double Bolting
00	None
ZZ	Non-Standard

15	Accessories
0	None
6	316SS Bolting
7	Hi-temperature Bolting
Z	Non-Standard

MARK 601 HIGH FLOW SELF-OPERATED PRESSURE REGULATORS

Jordan Valve offers a full range of pressure regulators in addition to the Mark 60 Self-Operated Pressure Regulator

Mark 62 Internally Piloted Pressure Regulator

The Mark 62 is a specialty valve designed for critical application regulation in locations where space is limited. Small and lightweight in design, the Mark 62 valve provides the accuracy of a piloted valve with the size, weight, and appearance of a single, self-operated valve.



Mark 63/64 Differential Pressure Regulators

The Mark 63 is designed to maintain a constant differential between the pressure on the discharge side of the regulator and the signal pressure loaded on the diaphragm. The Mark 64 provides the same flow capacity as the Mark 63 but with less offset in controlled pressure due to a larger diaphragm.



Mark 65 Vacuum Regulators

The Mark 65 vacuum regulators control very accurately and shutoff tightly to maintain the proper vacuum setting. They are used to maintain vacuums at predetermined settings and to regulate vacuums on evaporators, cookers, grinding fixtures, milking machines, altitude chambers and other vacuum systems.



Mark 66 Air-Loaded Pressure Regulators

The Mark 66 is a highly accurate and economical air loaded pressure regulator that provides regulation from a local station or from a remote station. The operation of the MK66 requires no control spring or pilot. Instead, a static signal is applied to the top of the diaphragm to determine the setpoint.



Mark 67 Pilot-Operated Pressure Regulators

The Mark 67 is for critical pressure reducing applications and provides a greater accuracy and lower offset than can be achieved with a self-operated regulator. Because of its versatility in control, and its accuracy, the Mark 67 can be used in a wide variety of applications including: controlling the pressure of gaseous oxygen to furnaces at steel mills, controlling pressure of sealing oil on turbines, and pressure control on steam mains and distribution lines.



Mark 68G Pressure Regulator

The Mark 68G is a globe-style pressure reducing regulating valve that offers high capacity, accurate regulation, and easy servicing, making it the ideal choice for your industrial-grade pressure reducing applications.



Mark 68HP High Pressure Regulating Valve

The Mark 68HP is designed primarily for high pressure steam service as commonly found in power plants, refineries, pulp & paper mills, and other high pressure process applications.



Jordan Valve a division of Richards Industries
 3170 Wasson Road • Cincinnati, OH 45209
 513.533.5600 • 800.543.7311 • 513.871.0105 (f)
 jordan@richardsind.com • www.jordanvalve.com