

Fluid metering

ST_f

POSITIVE DISPLACEMENT ADJUSTABLE DISPENSING PUMP

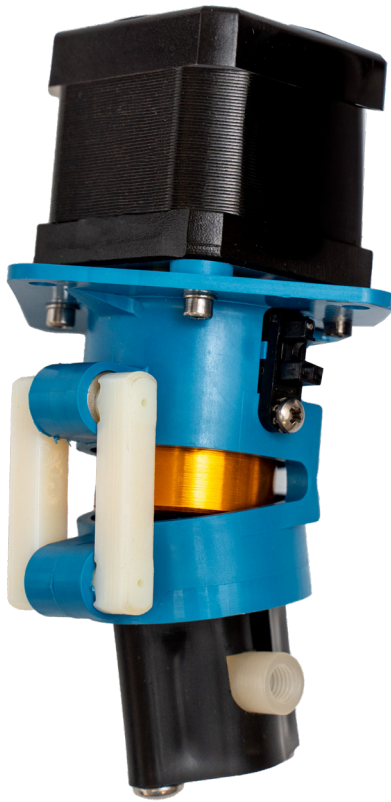

The ST_f is an advanced miniaturized fluidic system designed to control small volumes of fluid at the microscale level for a broad range of applications. It is currently available in standard drive configurations ranging from 5 μ L through 400 μ L in 1 μ L increments. Standard pump head options are available with various sealing options and diameters.

Achieving optimal performance in accuracy and repeatability with innovative design modifications, this product enables the ability to do precision microliter dispensing.

This technology is ideal for OEM life science applications including Diagnostics/IVD, Medical, Biotechnology, and Analytical Instrumentation.

FEATURES & BENEFITS

- CeramPump[®] valveless technology simplifies fluidic architecture with one moving part in fluid path
- Internal sapphire-hard ceramics are chemically inert, dimensionally stable, and abrasion resistant
- Patented fixed link adjustment mechanism
- Optical sensor for positioning feedback
- Configurable options available
- Minimal pulse for precise control and consistent, repeatable dispense volume
- Reduced shear stress protects delicate and organic samples from damage
- Quiet operation for controlled environments
- Less gas ingress prevents bubble formation
- Maintains 0.5% precision for millions of cycles without maintenance or recalibration

REV-G



Fluid Metering's facility is certified to the ISO 9001:2015 international standard. Product components are manufactured to meet EU RoHS and REACH compliance requirements.

Fluid metering STF

POSITIVE DISPLACEMENT ADJUSTABLE DISPENSING PUMP

PUMP SPECIFICATIONS

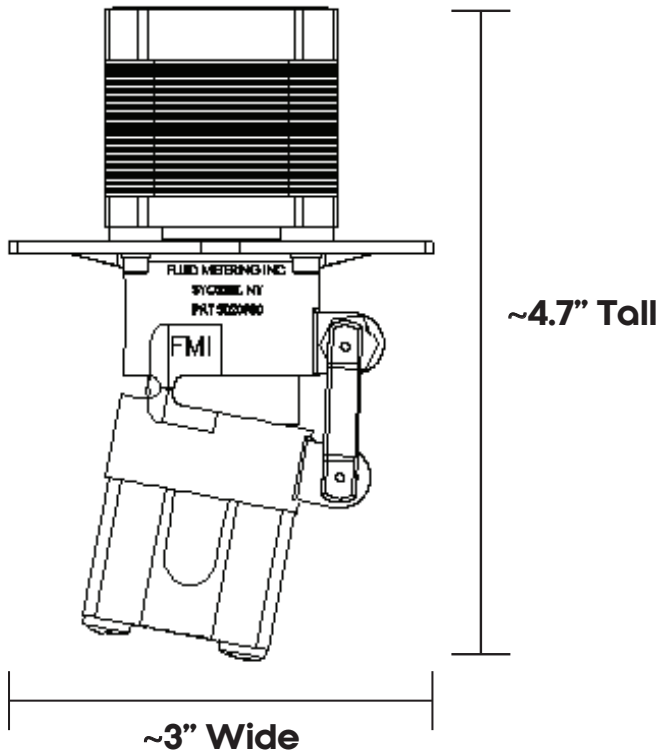

WETTED MATERIAL OPTIONS:

Ceramic: Alumina, Zirconia
Pump Housing: PVDF, ETFE, Polypropylene

SEAL MATERIAL OPTIONS:

Carbon-Filled PTFE, FKM, FFKM, Rulon AR, UHMW-PE

PORT OPTIONS:

1/4-28 UNC Threaded Ports,
Barb Fittings (1/8" - 1/4" Tubing ID),
1/4" Compression Nuts

DISPENSE VOLUME:

For 5 - 10 μ L

Accuracy of $\pm 5\%$
Precision (CV) $\leq 1\%$

For >10 - 400 μ L

Accuracy of $\pm 1\%$
Precision (CV) $\leq 0.5\%$

MOTOR/DRIVER SPECIFICATIONS

RATED CURRENT:

Rotational: 2.0A

MOTOR FRAME:

Rotational: NEMA 17 (43mm)

STEP ANGLE:

Rotational: 1.8° Full Step

MOTOR SPEED:

Rotational: Up to 1000 RPM

MOTOR DIRECTION:

Rotational: Bidirectional,
Calibrated Clockwise

OPERATING TEMPERATURE:

0°C to 50°C

F	Dispense Volume (μ L/rev)		Flow Rate (mL/min)	
	min	max	1 RPM	1000 RPM
STF				
STFSM	5	40	0.005	40
STF1	25	200	0.025	200
STF2	28	225	0.028	225
STF3	31	250	0.031	250
STF4	34	275	0.034	275
STF5	38	300	0.038	300
STF6	41	325	0.041	325
STF7	44	350	0.044	350
STF8	47	375	0.047	375
STF9	50	400	0.05	400

- Accuracy is a percentage of the target dispense volume.
- Maximum standard operating pressure at 100 (PSIG)
- Fixed Link pumps are calibrated in-house to a set volume and cannot be changed.
- Flow rate can be changed by adjusting motor speed.

CUSTOMIZED FLUIDIC SOLUTIONS

Be it a small tweak to existing technology or a full development project, our pumps and dispensers can be customized to accommodate dispense volume, flow rate, temperature, pressure, materials, and more.

Contact Us Today!

Rapid prototyping available within 10 business days*

*Prototype requests are subject to availability of parts and materials. Fluid Metering will confirm availability within 2 business days and provide an estimated shipping date.